

**FIREFEX**

# FIREFIGHTING WATER PUMPS

AVAILABLE IN GASOLINE & DIESEL ENGINE OPTIONS



## FIREFIGHTING WATER PUMPS EQUIPMENTS

Designed with high flexibility and portability, this unit allows for easy transport and rapid deployment across various conditions. Supported by a premium-quality pump, it ensures superior performance, strong water output, and long-term reliability in demanding firefighting operations.

[www.indotara.co.id](http://www.indotara.co.id)

# TABLE OF CONTENT

Explore our range of high-performance firefighting equipment designed for reliability, mobility, and efficient emergency response, delivering powerful performance & dependable operation in demanding conditions.

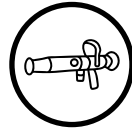

Advanced Multi-Pattern Spray

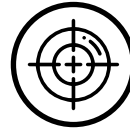

Precision Flow & Pressure Control



High-Pressure Performance



Powerful Pump & Engine Support



Compact & Portable Design



Reliable & Low Maintenance

## 01

### PORTABLE FIRE PUMP GASOLINE ENGINE

A lightweight, gasoline-powered portable fire pump built for fast deployment and dependable firefighting performance anytime, anywhere.

## 43

### HIGH-LIFT FOREST FIRE PUMP GASOLINE ENGINE

A gasoline-powered forest fire pump designed for high pressure and reliable performance in tough environments.

## 33

### PORTABLE FIRE PUMP DIESEL ENGINE

A portable diesel-powered fire pump designed for strong performance, durability, and reliable operation in demanding firefighting conditions.

## 49

### MULTI FUNCTION FIRE NOZZLE

A high-performance multi-function fire nozzle built for precise control and adaptable perfect for firefighting performance.

## 37

### FLOATING FIRE PUMP GASOLINE ENGINE

A gasoline-powered floating fire pump designed for rapid deployment, strong water output, and reliable performance directly on water surfaces.

### FIREFIGHTING WATER PUMPS EQUIPMENTS

Designed with high flexibility and portability, this unit allows for easy transport and rapid deployment across various conditions. Supported by a premium-quality pump, it ensures superior performance, strong water output, and long-term reliability in demanding firefighting operations.

# PORTABLE FIRE PUMP GASOLINE ENGINE



## TYPE **FPF3.0/33.5-BS**

### Engine

BRIGGS 6134  
4 STROKES, AIR COOLED  
GASOLINE ENGINE

### Max. Output

46HP (33.8Kw)

### Pump performance

1230L/Min @ 0.5 MPa  
2015L/Min @ 0.3 MPa  
2500L/Min @ 0.1 MPa

### Net weight

120kg

### Size

765 x 738 x 705 mm



### Main Components

- ▶ Electric starter
- ▶ 90° rotatable discharge valve
- ▶ Oil-free brass vacuum pump
- ▶ Genuine engine
- ▶ Large flow, medium-high head
- ▶ Double discharge valve
- ▶ Oil-free carbon fiber slide vane
- ▶ Automatic shutdown protection device

### Trolley Design

Can be lifted by hand or pushed, making it more convenient and efficient to use.

### Original engine power upgrade

Improve the air intake system and fine-tune the injection timing to achieve more complete combustion. Adjust the primary coil voltage of the ignition coil to enhance the secondary coil's electromagnetic performance, thereby increasing the engine's overall power.

### Intelligent Control Panel

The new integrated control panel features one-button start and enables one-button suction, water discharge, and other functions. No professional training is required, making operation simpler while ensuring the equipment runs normally.

### Oil-Free Vacuum Pump

The improved vacuum pump cavity delivers twice the exhaust volume of the original. Air can be evacuated in a shorter time, making the pumping process more efficient. Water discharge is faster, with a priming time of ≤15 seconds, and a maximum suction height of up to 9 meters.



# PORTABLE FIRE PUMP



## Mobility Meets Firefighting Power

A high-powered, easy-to-carry fire pump engineered for superior performance and mobility. Delivering strong, consistent water pressure, it is ready to operate anytime, anywhere—providing dependable fire protection across emergency scenarios, industrial environments, and remote areas.

Engine Type	4 Strokes	Pump Type	Single stage centrifugal pump
Cylinders	2 Cylinders	Inlet Diameter	Φ110 mm
Bore x Stroke	86.5 x 85.5 mm	Outlet Diameter	Φ80 mm
Fuel Type	92# and above	Outlets	2 Pcs
Fuel Tank	≥ 10L (Polyurethane fuel tank with high strength and high temperature resistant)	Outlet Valve	Flat check valve
Fuel System	Carburetor (manual choke)	Priming System	Free oil rotary vane bronze vacuum pump
Lubrication System	Forced Lubrication	Suction Time	≤ 20 s
Oil Capacity	23 L	Max. Suction Head	9 m
Start Method	Electric Start	Max. Pump Head	65 m
Ignition Method	Transistor electronic ignition	Rated flow	2015 L/Min
Fuel Consumption	10 L/H	Rated Pressure	0.3 MPa
Net Weight	120 kg	Max. Flow	2500 L/Min

### Size (mm)

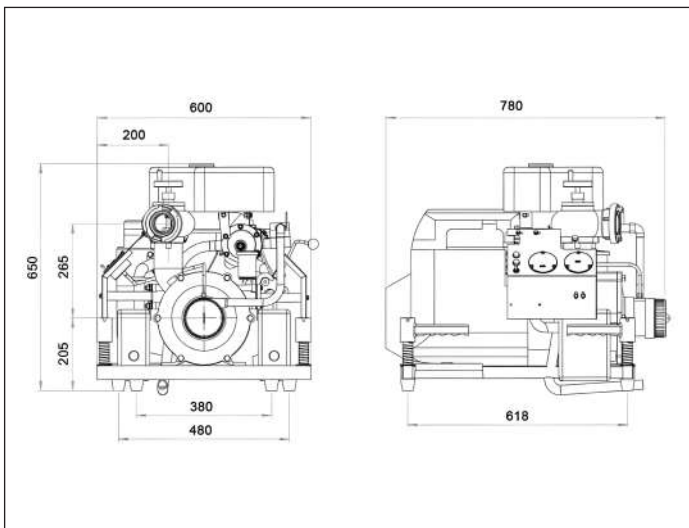

### Performance curve

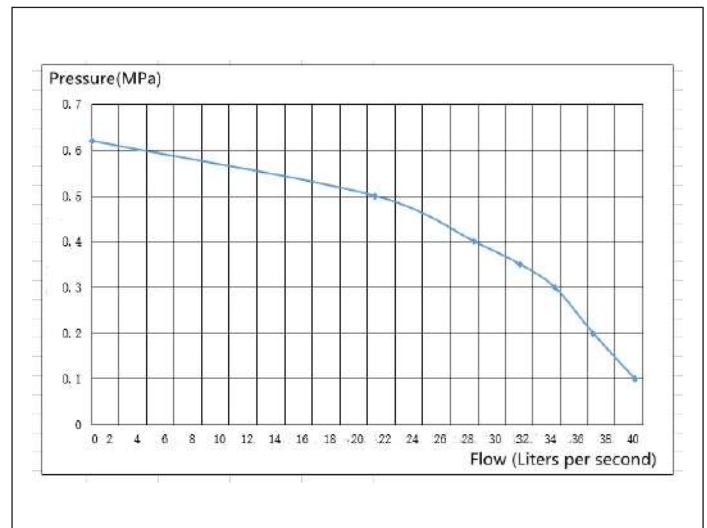

# PORTABLE FIRE PUMP GASOLINE ENGINE



## TYPE **FPF3.0/33.5-FR**

### Engine

FIREFEX FR999  
4 STROKES, AIR COOLED  
GASOLINE ENGINE

### Max. Output

46HP (33.8Kw)

### Pump performance

1230L/Min @ 0.5 MPa  
2015L/Min @ 0.3 MPa  
2500L/Min @ 0.1 MPa

### Net weight

120kg

### Size

765 x 738 x 705 mm



### Main Components

- ▶ Electric starter
- ▶ 90° rotatable discharge valve
- ▶ Oil-free brass vacuum pump
- ▶ Genuine engine
- ▶ Large flow, medium-high head
- ▶ Double discharge valve
- ▶ Oil-free carbon fiber slide vane
- ▶ Automatic shutdown protection device

### Trolley Design

Can be lifted by hand or pushed, making it more convenient and efficient to use.

### Original engine power upgrade

Improve the air intake system and fine-tune the injection timing to achieve more complete combustion. Adjust the primary coil voltage of the ignition coil to enhance the secondary coil's electromagnetic performance, thereby increasing the engine's overall power.

### Intelligent Control Panel

The new integrated control panel features one-button start and enables one-button suction, water discharge, and other functions. No professional training is required, making operation simpler while ensuring the equipment runs normally.

### Oil-Free Vacuum Pump

The improved vacuum pump cavity delivers twice the exhaust volume of the original. Air can be evacuated in a shorter time, making the pumping process more efficient. Water discharge is faster, with a priming time of ≤15 seconds, and a maximum suction height of up to 9 meters.



# PORTABLE FIRE PUMP



## Mobility Meets Firefighting Power

A high-powered, easy-to-carry fire pump engineered for superior performance and mobility. Delivering strong, consistent water pressure, it is ready to operate anytime, anywhere—providing dependable fire protection across emergency scenarios, industrial environments, and remote areas.

Engine Type	4 Strokes	Pump Type	Single stage centrifugal pump
Cylinders	2 Cylinders	Inlet Diameter	Φ110 mm
Bore x Stroke	86.5 x 85.5 mm	Outlet Diameter	Φ80 mm
Fuel Type	92# and above	Outlets	2 Pcs
Fuel Tank	≥ 10L (Polyurethane fuel tank with high strength and high temperature resistant)	Outlet Valve	Flat check valve
Fuel System	Carburetor (manual choke)	Priming System	Free oil rotary vane bronze vacuum pump
Lubrication System	Forced Lubrication	Suction Time	≤ 20 s
Oil Capacity	23 L	Max. Suction Head	9 m
Start Method	Electric Start	Max. Pump Head	65 m
Ignition Method	Transistor electronic ignition	Rated flow	2015 L/Min
Fuel Consumption	10 L/H	Rated Pressure	0.3 MPa
Net Weight	120 kg	Max. Flow	2500 L/Min

### Size (mm)

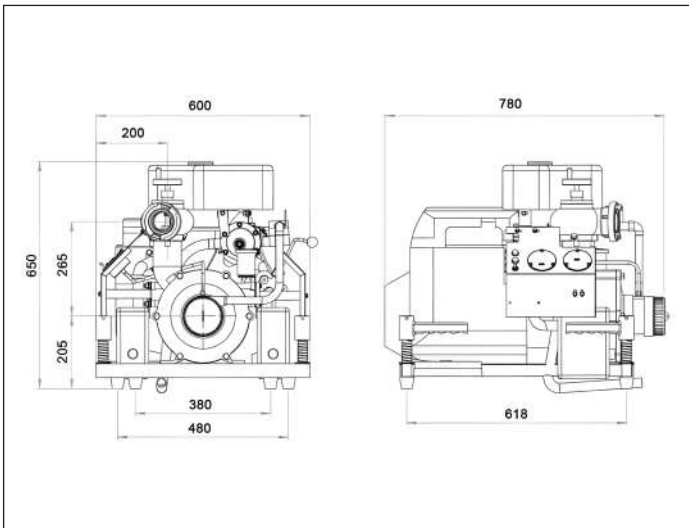

### Performance curve

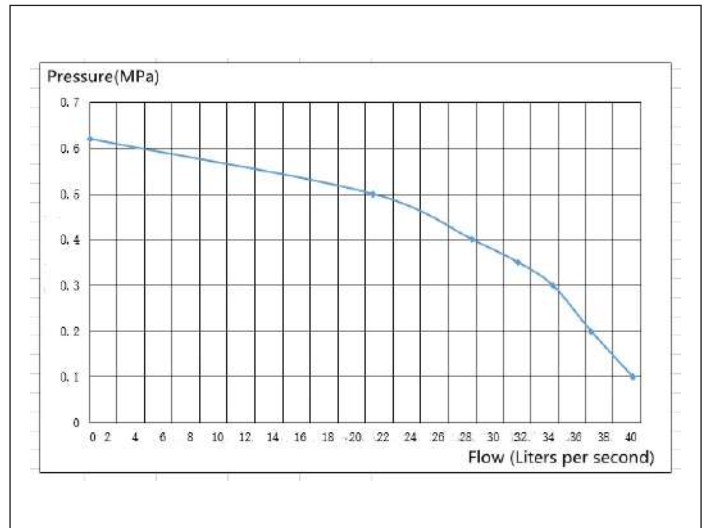

# PORTABLE FIRE PUMP GASOLINE ENGINE



## TYPE FPF8.5/17-FR

### Engine

FIREFEX FR999  
4 STROKES, AIR COOLED  
GASOLINE ENGINE

### Max. Output

46HP (33.8Kw)

### Pump performance

840L/Min @ 1.0 MPa  
1020L/Min @ 0.85 MPa  
1500L/Min @ 0.5 MPa

### Net weight

99.5 kg

### Size

745 x 738 x 705 mm



### Main Components

- ▶ Electric starter
- ▶ 90° rotatable discharge valve
- ▶ Oil-free brass vacuum pump
- ▶ Genuine engine
- ▶ Large flow, medium-high head
- ▶ Single discharge valve
- ▶ Oil-free carbon fiber slide vane
- ▶ Automatic shutdown protection device

### Trolley Design

Can be lifted by hand or pushed, making it more convenient and efficient to use.

### Original engine power upgrade

Improve the air intake system and fine-tune the injection timing to achieve more complete combustion. Adjust the primary coil voltage of the ignition coil to enhance the secondary coil's electromagnetic performance, thereby increasing the engine's overall power.

### Intelligent Control Panel

The new integrated control panel features one-button start and enables one-button suction, water discharge, and other functions. No professional training is required, making operation simpler while ensuring the equipment runs normally.

### Oil-Free Vacuum Pump

The improved vacuum pump cavity delivers twice the exhaust volume of the original. Air can be evacuated in a shorter time, making the pumping process more efficient. Water discharge is faster, with a priming time of  $\leq 15$  seconds, and a maximum suction height of up to 9 meters.



# PORTABLE FIRE PUMP



## Mobility Meets Firefighting Power

A high-powered, easy-to-carry fire pump engineered for superior performance and mobility. Delivering strong, consistent water pressure, it is ready to operate anytime, anywhere—providing dependable fire protection across emergency scenarios, industrial environments, and remote areas.

Engine Type	4 Strokes	Pump Type	Double Stage
Cylinders	2 Cylinders	Inlet Diameter	Ø80 mm
Bore x Stroke	90 x 78.5 mm	Outlet Diameter	Ø65 mm
Fuel Type	92# and above	Outlets	1 pc
Fuel Tank	12 L	Outlet Valve	Flat check valve
Fuel System	Electromagnetic Valve Carburetor (Manual Choke)	Priming System	Free oil rotary vane bronze vacuum pump
Lubrication System	Forced Lubrication	Suction Time	≤8.2 s
Oil Capacity	23 L	Max. Suction Head	9 m
Start Method	Electric Start (Recoil starter can be assembled)	Max. Pump Head	145 m
Ignition Method	Transistor Electronic Ignition	Rated flow	1020 L/Min
Fuel Consumption	11 L/H	Rated Pressure	0.85 MPa
Net Weight	99.5 kg		

### Performance curve

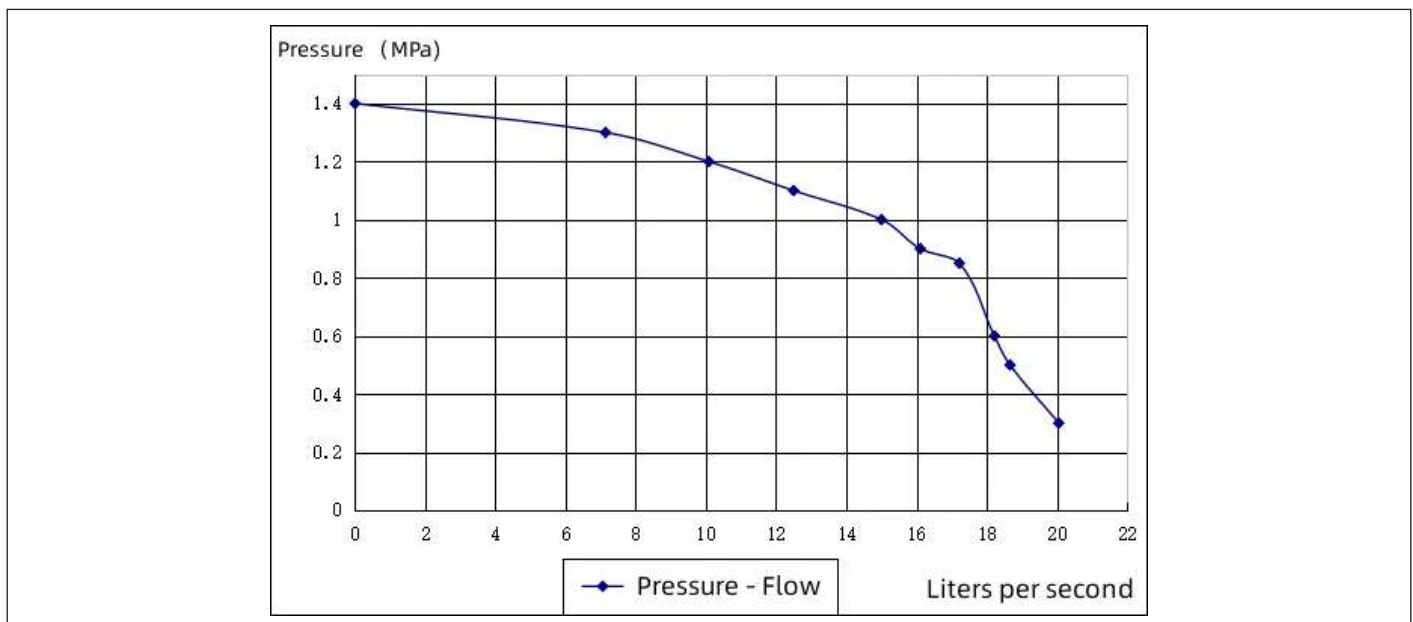

# PORTABLE FIRE PUMP GASOLINE ENGINE



## TYPE FPF10.0/13-FR

### Engine

FIREFEX FR999  
4 STROKES, AIR COOLED  
GASOLINE ENGINE

### Max. Output

46HP (33.8Kw)

### Pump performance

840L/Min @ 1.0 MPa  
1020L/Min @ 0.85 MPa  
1500L/Min @ 0.5 MPa

### Net weight

99.5 kg

### Size

745 x 738 x 705 mm



### Main Components

- ▶ Electric starter
- ▶ 90° rotatable discharge valve
- ▶ Oil-free brass vacuum pump
- ▶ Genuine engine
- ▶ Large flow, medium-high head
- ▶ Single discharge valve
- ▶ Oil-free carbon fiber slide vane
- ▶ Automatic shutdown protection device

### Trolley Design

Can be lifted by hand or pushed, making it more convenient and efficient to use.

### Original engine power upgrade

Improve the air intake system and fine-tune the injection timing to achieve more complete combustion. Adjust the primary coil voltage of the ignition coil to enhance the secondary coil's electromagnetic performance, thereby increasing the engine's overall power.

### Intelligent Control Panel

The new integrated control panel features one-button start and enables one-button suction, water discharge, and other functions. No professional training is required, making operation simpler while ensuring the equipment runs normally.

### Oil-Free Vacuum Pump

The improved vacuum pump cavity delivers twice the exhaust volume of the original. Air can be evacuated in a shorter time, making the pumping process more efficient. Water discharge is faster, with a priming time of  $\leq 15$  seconds, and a maximum suction height of up to 9 meters.



# PORTABLE FIRE PUMP



## Mobility Meets Firefighting Power

A high-powered, easy-to-carry fire pump engineered for superior performance and mobility. Delivering strong, consistent water pressure, it is ready to operate anytime, anywhere—providing dependable fire protection across emergency scenarios, industrial environments, and remote areas.

Engine Type	4 Strokes	Pump Type	Double Stage
Cylinders	2 Cylinders	Inlet Diameter	Ø80 mm
Bore x Stroke	90 x 78.5 mm	Outlet Diameter	Ø65 mm
Fuel Type	92# and above	Outlets	1 pc
Fuel Tank	12 L	Outlet Valve	Flat check valve
Fuel System	Electromagnetic Valve Carburetor (Manual Choke)	Priming System	Free oil rotary vane bronze vacuum pump
Lubrication System	Forced Lubrication	Suction Time	≤8.2 s
Oil Capacity	23 L	Max. Suction Head	9 m
Start Method	Electric Start (Recoil starter can be assembled)	Max. Pump Head	145 m
Ignition Method	Transistor Electronic Ignition	Rated flow	1020 L/Min
Fuel Consumption	11 L/H	Rated Pressure	1.0 MPa
Net Weight	99.5 kg		

### Performance curve

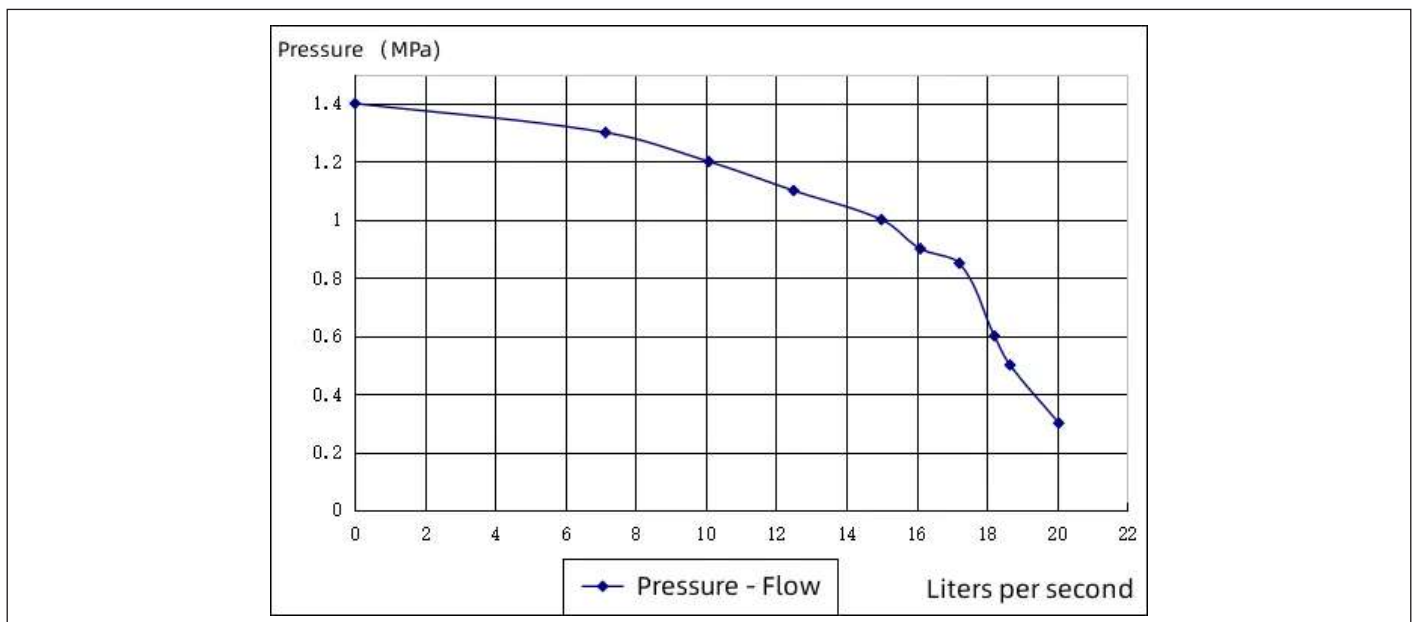

# PORTABLE FIRE PUMP GASOLINE ENGINE



## TYPE FPF6.5/24-BS

### Engine

BRIGGS & STRATTON 6134  
4 STROKES, AIR COOLED  
GASOLINE ENGINE

### Max. Output

46HP (33.8Kw)

### Pump performance

895L/Min @ 0.8 MPa  
1440L/Min @ 0.65 MPa  
1596L/Min @ 0.5 MPa

### Net weight

115kg

### Size

745 x 735 x 704 mm



### Main Components

- ▶ Electric starter
- ▶ 90° rotatable discharge valve
- ▶ Oil-free brass vacuum pump
- ▶ Genuine engine
- ▶ Large flow, medium-high head
- ▶ Single discharge valve
- ▶ Oil-free carbon fiber slide vane
- ▶ Automatic shutdown protection device

### Trolley Design

Can be lifted by hand or pushed, making it more convenient and efficient to use.

### Original engine power upgrade

Improve the air intake system and fine-tune the injection timing to achieve more complete combustion. Adjust the primary coil voltage of the ignition coil to enhance the secondary coil's electromagnetic performance, thereby increasing the engine's overall power.

### Intelligent Control Panel

The new integrated control panel features one-button start and enables one-button suction, water discharge, and other functions. No professional training is required, making operation simpler while ensuring the equipment runs normally.

### Oil-Free Vacuum Pump

The improved vacuum pump cavity delivers twice the exhaust volume of the original. Air can be evacuated in a shorter time, making the pumping process more efficient. Water discharge is faster, with a priming time of ≤15 seconds, and a maximum suction height of up to 9 meters.



# PORTABLE FIRE PUMP



## Mobility Meets Firefighting Power

A high-powered, easy-to-carry fire pump engineered for superior performance and mobility. Delivering strong, consistent water pressure, it is ready to operate anytime, anywhere—providing dependable fire protection across emergency scenarios, industrial environments, and remote areas.

Engine Type	4 Strokes	Pump Type	Single stage centrifugal pump
Cylinders	2 Cylinders	Inlet Diameter	Ø90 mm
Bore x Stroke	86.5 x 85.5 mm	Outlet Diameter	Ø80 mm
Fuel Type	92# and above	Outlets	1 pc
Fuel Tank	≥10L (Polyurethane fuel tank with high strength and high temperature resistant)	Outlet Valve	Flat check valve
Fuel System	Carburetor - Manualchoke	Priming System	Free oil rotary vane bronze vacuum pump
Lubrication System	Forced Lubrication	Suction Time	≤15 s
Oil Capacity	2.3 L	Max. Suction Head	9 m
Start Method	Electric Start (Recoil starter can be assembled)	Max. Pump Head	90 m
Ignition Method	Transistor electronic ignition	Rated flow	1440 L/Min
Fuel Consumption	10 L/H	Rated Pressure	0.65 MPa
Net Weight	115 kg	Max. Flow	2000 L/Min

### Performance curve

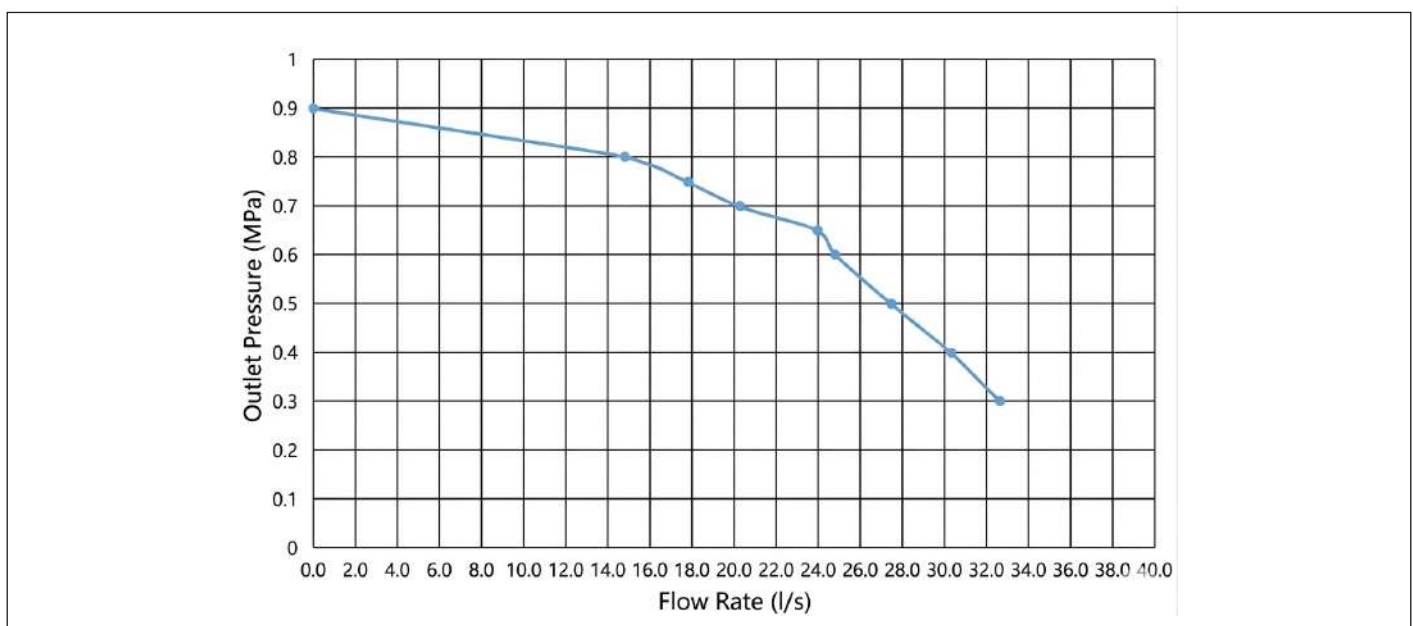

# PORTABLE FIRE PUMP GASOLINE ENGINE



## TYPE FPF6.5/24-FR

### Engine

FIREFEX FR999  
4 STROKES, AIR COOLED  
GASOLINE ENGINE

### Max. Output

46HP (33.8Kw)

### Pump performance

895L/Min @ 0.8 MPa  
1440L/Min @ 0.65 MPa  
1596L/Min @ 0.5 MPa

### Net weight

115kg

### Size

745 x 735 x 704 mm



### Main Components

- ▶ Electric starter
- ▶ 90° rotatable discharge valve
- ▶ Oil-free brass vacuum pump
- ▶ Genuine engine
- ▶ Large flow, medium-high head
- ▶ Single discharge valve
- ▶ Oil-free carbon fiber slide vane
- ▶ Automatic shutdown protection device

### Trolley Design

Can be lifted by hand or pushed, making it more convenient and efficient to use.

### Original engine power upgrade

Improve the air intake system and fine-tune the injection timing to achieve more complete combustion. Adjust the primary coil voltage of the ignition coil to enhance the secondary coil's electromagnetic performance, thereby increasing the engine's overall power.

### Intelligent Control Panel

The new integrated control panel features one-button start and enables one-button suction, water discharge, and other functions. No professional training is required, making operation simpler while ensuring the equipment runs normally.

### Oil-Free Vacuum Pump

The improved vacuum pump cavity delivers twice the exhaust volume of the original. Air can be evacuated in a shorter time, making the pumping process more efficient. Water discharge is faster, with a priming time of ≤15 seconds, and a maximum suction height of up to 9 meters.



# PORTABLE FIRE PUMP



## Mobility Meets Firefighting Power

A high-powered, easy-to-carry fire pump engineered for superior performance and mobility. Delivering strong, consistent water pressure, it is ready to operate anytime, anywhere—providing dependable fire protection across emergency scenarios, industrial environments, and remote areas.

Engine Type	4 Strokes	Pump Type	Single stage centrifugal pump
Cylinders	2 Cylinders	Inlet Diameter	Ø90mm
Bore x Stroke	86.5x85.5 mm	Outlet Diameter	Ø80mm
Fuel Type	92# and above	Outlets	1Pc
Fuel Tank	≥10L (Polyurethane fuel tank with high strength and high temperature resistant)	Outlet Valve	Flat check valve
Fuel System	Carburetor - Manualchoke	Priming System	Free oil rotary vane bronze vacuum pump
Lubrication System	Forced Lubrication	Suction Time	≤15S
Oil Capacity	2.3L	Max. Suction Head	9M
Start Method	Electric Start (Recoil starter can be assembled)	Max. Pump Head	90M
Ignition Method	Transistor electronic ignition	Rated flow	1440L/Min
Fuel Consumption	10L/H	Rated Pressure	0.65MPa
Net Weight	115 Kg	Max. Flow	2000L/Min

### Performance curve

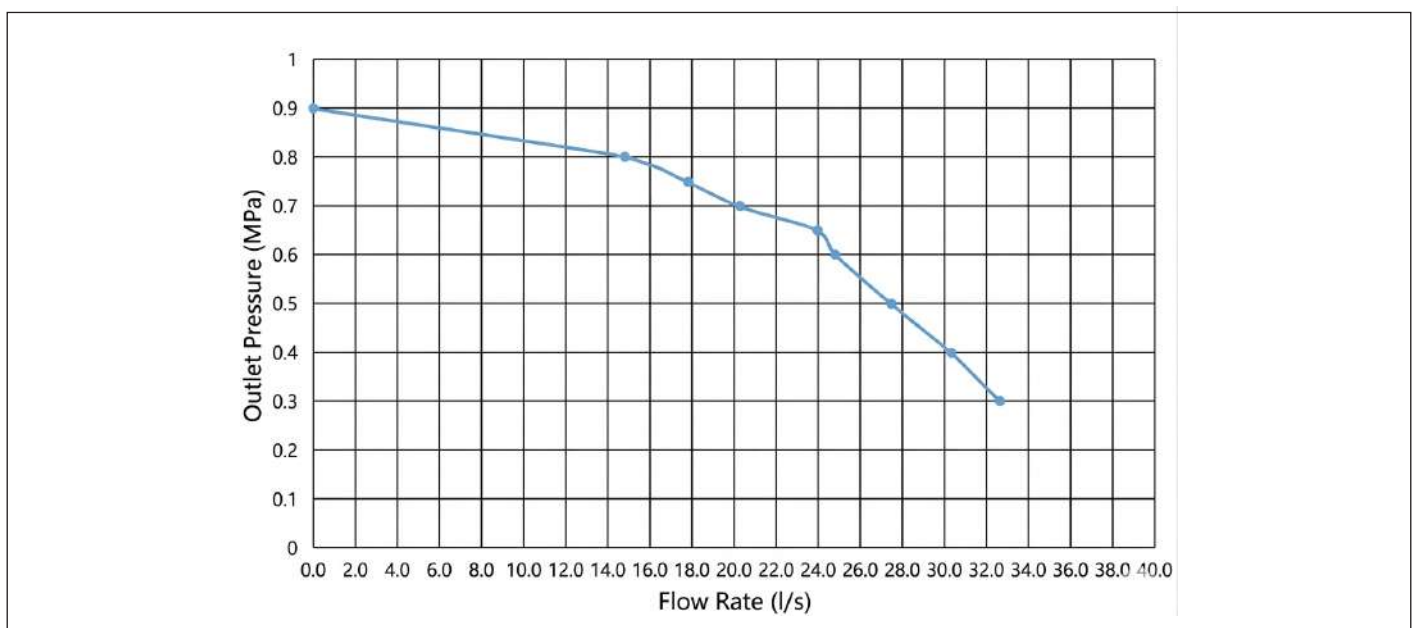

# PORTABLE FIRE PUMP GASOLINE ENGINE



## TYPE **FPF6.0/17-FR**

### Engine

FIREFEX FR740 DISPLACEMENT: 740CC  
4 STROKES, AIR COOLED  
GASOLINE ENGINE

### Max. Output

27HP (20Kw)

### Pump performance

(TEST: Under 3M Suction Depth)

1020L/Min @ 0.60 MPa

1260L/Min @ 0.40 MPa

1500L/Min @ 0.20 MPa

### Net weight

95 kg

### Size

655 x 618 x 616 mm



Gasoline engine series portable fire pumps are manufactured using original imported or well-known domestic brand engines, along with centrifugal pumps produced by Firefex.

They offer the advantages of light weight, compact structure, easy start-up, fast water output, low fuel consumption, high head, large flow capacity, and stable, reliable performance.

These pumps are suitable for use in flammable and explosive environments, such as industrial facilities, oil depots, docks, and ships, as well as other units requiring emergency fire response. They can also be used for flood control and drainage, long-distance water supply for drought relief, site cleaning, and other emergency operations.

### Oil-Free Vacuum Pump

The improved vacuum pump cavity delivers twice the exhaust volume of the original. Air can be evacuated in a shorter time, making the pumping process more efficient. Water discharge is faster, with a priming time of  $\leq 15$  seconds, and a maximum suction height of up to 9 meters.

### Original Engine Power Upgrade

Improve the air intake system and fine-tune the injection timing to achieve more complete combustion. Adjust the primary coil voltage of the ignition coil to enhance the secondary coil's electromagnetic performance, thereby increasing the engine's overall power.

### Multiple Device Connection

Using a dedicated connection tool, multiple units can be connected in series and operate simultaneously to enable long-distance water supply.



# PORTABLE FIRE PUMP



## Mobility Meets Firefighting Power

### Intelligent Control Panel

The new integrated intelligent control panel features one-button start and automatic water priming, water discharge, and other functions. It requires no professional training, offers simpler operation, and ensures reliable equipment performance.

### Maintenance-Free Battery

Equipped with an electric start function, the system effectively prevents environmental pollution caused by electrolyte leakage. The battery is stable and reliable, ensuring the equipment can start normally anytime and anywhere.

### Automatic Charging Device

The equipment is equipped with an automatic charging function that allows the battery to be charged during operation, ensuring it remains fully charged at all times.

Cylinders	Double Cylinders	Pump Specification	Single suction, single stage
Bore x Stroke	78 x 72 mm	Inlet Diameter	3" (80mm)
Max. Output	27HP (20KW)	Outlet Diameter	2.5" (65mm)
Fuel Type	Gasoline 92# and above	Number of outlets	1 or 2
Fuel Tank	12 L	Outlet valve type	Flat check valve
Fuel System	Carburetor - Manualchoke	Priming System	Oil free vacuum pump
Lubrication System	Forced Lubrication	Suction Time	≤15 s
Engine Oil Capacity	1.5 L	Max. Suction Head	9 m
Starter	Manual / Electric start	Max. Pump Head	90 m
Ignition Method	Transistor electronic ignition	Rated flow	1020 L/Min
Fuel Consumption	7 L/H	Rated Pressure	0.6 MPa

### Size (mm)

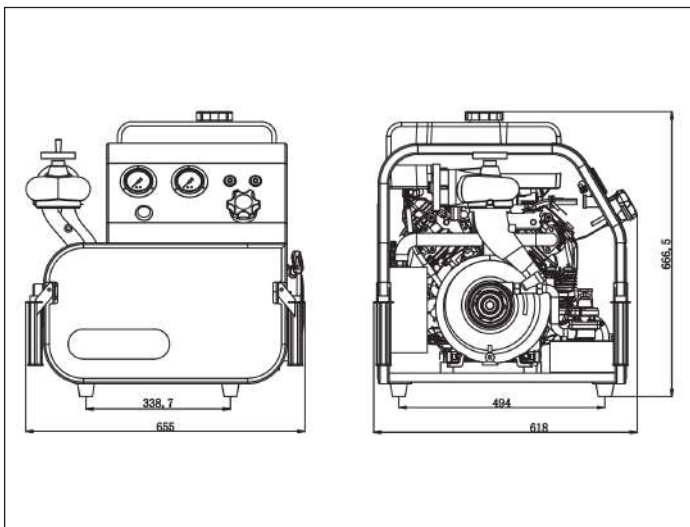

### Performance curve

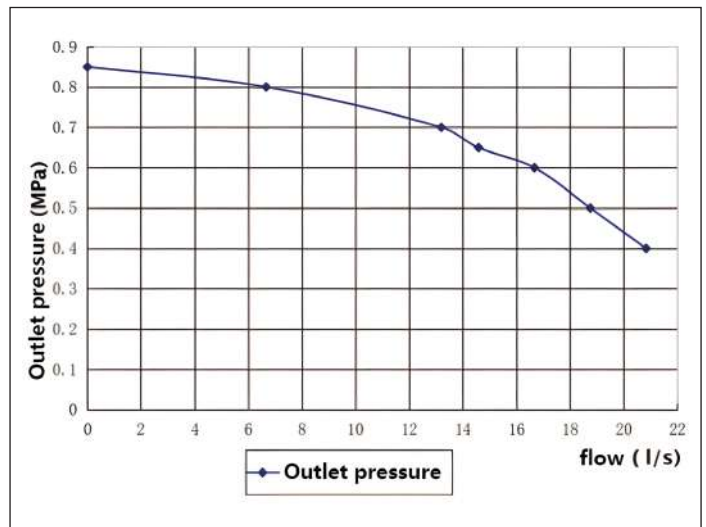

# PORTABLE FIRE PUMP GASOLINE ENGINE



## TYPE **FPF6.0/17-H**

### Engine

HONDA GX690 DISPLACEMENT: 688CC  
4 STROKES, AIR COOLED  
GASOLINE ENGINE

### Max. Output

27HP (20Kw)

### Pump performance

(TEST: Under 3M Suction Depth)

1020L/Min @ 0.60 MPa

1260L/Min @ 0.40 MPa

1500L/Min @ 0.20 MPa

### Net weight

95 kg

### Size

655 x 618 x 616 mm



Gasoline engine series portable fire pumps are manufactured using original imported or well-known domestic brand engines, along with centrifugal pumps produced by Firefex.

They offer the advantages of light weight, compact structure, easy start-up, fast water output, low fuel consumption, high head, large flow capacity, and stable, reliable performance.

These pumps are suitable for use in flammable and explosive environments, such as industrial facilities, oil depots, docks, and ships, as well as other units requiring emergency fire response. They can also be used for flood control and drainage, long-distance water supply for drought relief, site cleaning, and other emergency operations.

### Oil-Free Vacuum Pump

The improved vacuum pump cavity delivers twice the exhaust volume of the original. Air can be evacuated in a shorter time, making the pumping process more efficient. Water discharge is faster, with a priming time of  $\leq 15$  seconds, and a maximum suction height of up to 9 meters.

### Original Engine Power Upgrade

Improve the air intake system and fine-tune the injection timing to achieve more complete combustion. Adjust the primary coil voltage of the ignition coil to enhance the secondary coil's electromagnetic performance, thereby increasing the engine's overall power.

### Multiple Device Connection

Using a dedicated connection tool, multiple units can be connected in series and operate simultaneously to enable long-distance water supply.



# PORTABLE FIRE PUMP



## Mobility Meets Firefighting Power

### Intelligent Control Panel

The new integrated intelligent control panel features one-button start and automatic water priming, water discharge, and other functions. It requires no professional training, offers simpler operation, and ensures reliable equipment performance.

### Maintenance-Free Battery

Equipped with an electric start function, the system effectively prevents environmental pollution caused by electrolyte leakage. The battery is stable and reliable, ensuring the equipment can start normally anytime and anywhere.

### Automatic Charging Device

The equipment is equipped with an automatic charging function that allows the battery to be charged during operation, ensuring it remains fully charged at all times.

Cylinders	Double Cylinders	Pump Specification	Single suction, single stage
Bore x Stroke	78 x 72 mm	Inlet Diameter	3" (80mm)
Max. Output	27HP (20KW)	Outlet Diameter	2.5" (65mm)
Fuel Type	Gasoline 92# and above	Number of outlets	1 or 2
Fuel Tank	12 L	Outlet valve type	Flat check valve
Fuel System	Carburetor - Manualchoke	Priming System	Oil free vacuum pump
Lubrication System	Forced Lubrication	Suction Time	≤15 s
Engine Oil Capacity	1.5 L	Max. Suction Head	9 m
Starter	Manual / Electric start	Max. Pump Head	90 m
Ignition Method	Transistor electronic ignition	Rated flow	1020 L/Min
Fuel Consumption	7 L/H	Rated Pressure	0.6 MPa

### Size (mm)

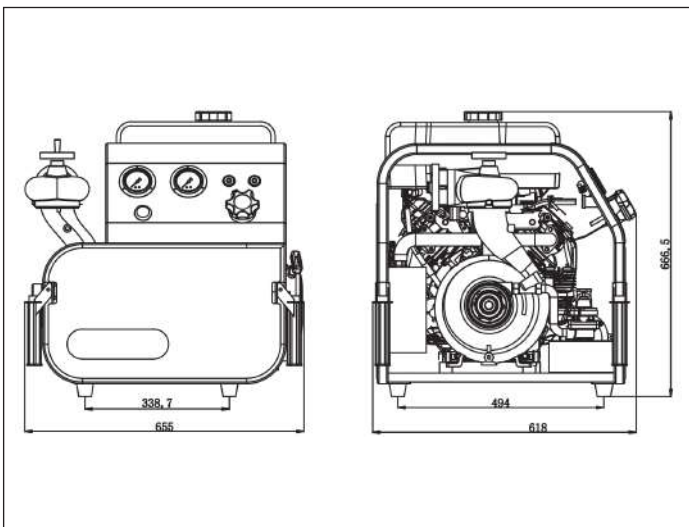

### Performance curve

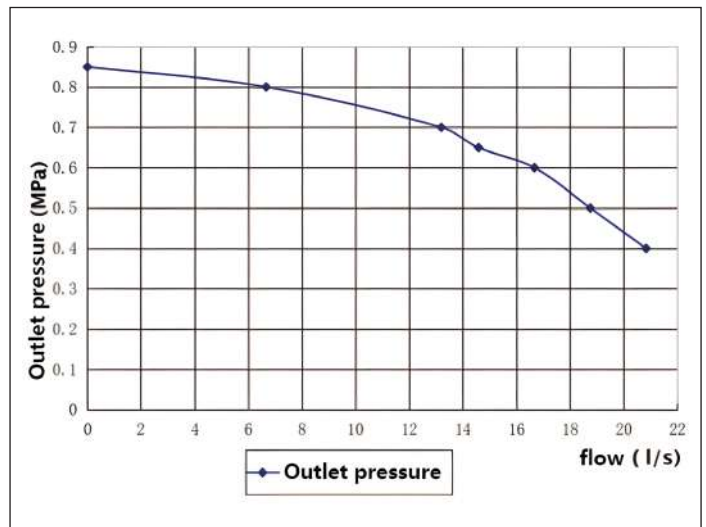

# PORTABLE FIRE PUMP GASOLINE ENGINE



## TYPE **FPF6.0/14.5-F**

### Engine

FIREFEX F2V78F  
4 STROKES, AIR COOLED  
GASOLINE ENGINE

### Max. Output

27HP (16.2Kw)

### Pump performance (3M Suction Depth)

900 L/Min @ 0.60 MPa  
1150 L/Min @ 0.40 MPa  
1500 L/Min @ 0.20 MPa

### Net weight

85 kg

### Size

690 x 600 x 630 mm



### Main Components

- ▶ Manual / Electric Start (Dual Starters)
- ▶ Rotary Vane Bronze Vacuum Pump
- ▶ Medium Flow, Medium Head
- ▶ Carbon Fiber Sliding Vanes
- ▶ 90° Rotatable Outlet Valve
- ▶ Original Imported Gasoline Engine

### Dual Shock Absorbers

Equipped with specialized dual shock absorbers, the machine remains stable during operation.

### Low Noise

The well-designed, large-capacity exhaust system effectively absorbs engine noise, significantly reducing noise pollution.

### Automatic Charging Device

The equipment is equipped with an automatic charging function that allows the battery to charge during operation, ensuring it remains fully charged at all times.

### Multiple Device Connection

Using a dedicated connection tool, multiple units can be connected in series and operate simultaneously to enable long-distance water supply.



# PORTABLE FIRE PUMP



## Mobility Meets Firefighting Power

A high-powered, easy-to-carry fire pump engineered for superior performance and mobility. Delivering strong, consistent water pressure, it is ready to operate anytime, anywhere—providing dependable fire protection across emergency scenarios, industrial environments, and remote areas.

Engine Model	4 Strokes	Inlet Diameter	3" (80 mm)
Cylinders	Double Cylinders	Outlet Diameter	2.5" (65 mm)
Fuel Type	Gasoline (92# and above)	Number of Outlets	1 or 2
Fuel Tank Capacity	7 L	Outlet Valve Type	Flat Check Valve
Fuel System	Carburetor (Manual Choke)	Suction Time	≤10 s
Lubrication System	Forced Lubrication	Priming System	Rotary Vane Vacuum Pump
Engine Oil Capacity	1.6 L	Max. Suction Head	9 m
Starter	Recoil / Electric Start	Max. Pump Head	85 m
Ignition Method	Transistor Electronic Ignition	Max. Flow	1500 L/min
Pump Type	Single-Stage Centrifugal Pump	Rated Flow	900 L/min
Fuel Consumption	6 L/h	Rated Pressure	0.6 MPa
Max. Output	27 HP (16.2 kW)	Net Weight	85 kg

### Size (mm)

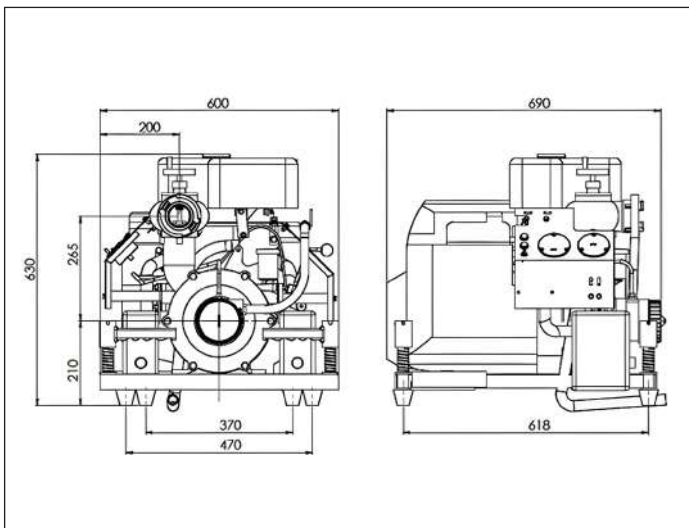

### Performance curve

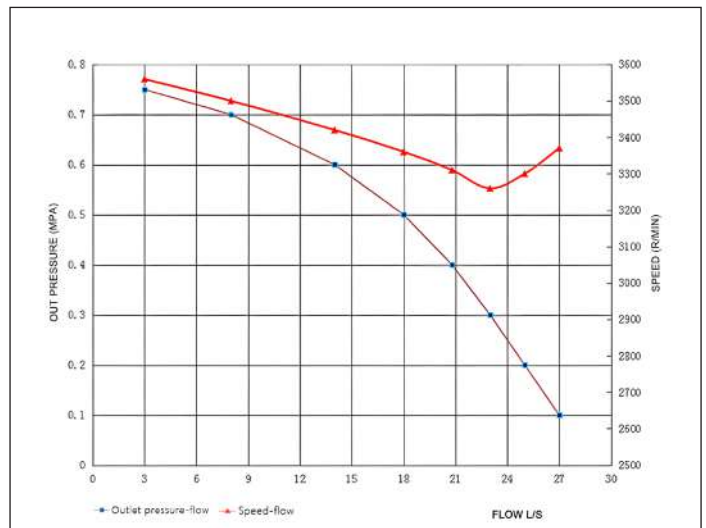

# PORTABLE FIRE PUMP GASOLINE ENGINE



## TYPE FPF6.0/14.5-H

### Engine

HONDA GX690, DISPLACEMENT: 688 CC  
4 STROKES, AIR COOLED  
GASOLINE ENGINE

### Max. Output

27HP (20Kw)

### Pump performance

(Tested at 3 m Suction Depth)

870 L/min @ 0.60 MPa

1180 L/min @ 0.40 MPa

1500 L/min @ 0.20 MPa

### Net weight

85 kg

### Size

690 x 600 x 630 mm



### Main Components

- ▶ Manual / Electric Start (Dual Starters)
- ▶ Rotary Vane Bronze Vacuum Pump
- ▶ Medium Flow, Medium Head
- ▶ Carbon Fiber Sliding Vanes
- ▶ 90° Rotatable Outlet Valve
- ▶ Original Imported Gasoline Engine

### Hand Start Device

Equipped with a self-retracting pull-start mechanism, the unit enables emergency starting when the battery voltage is low or when electric start is unavailable.

### Low Noise

The well-designed, large-capacity exhaust system effectively absorbs engine noise, significantly reducing noise pollution.

### Automatic Charging Device

The equipment is equipped with an automatic charging function that allows the battery to charge during operation, ensuring it remains fully charged at all times.

### Multiple Device Connection

Using a dedicated connection tool, multiple units can be connected in series and operate simultaneously to enable long-distance water supply.



# PORTABLE FIRE PUMP



## Mobility Meets Firefighting Power

A high-powered, easy-to-carry fire pump engineered for superior performance and mobility. Delivering strong, consistent water pressure, it is ready to operate anytime, anywhere—providing dependable fire protection across emergency scenarios, industrial environments, and remote areas.

Engine Model	4 Strokes	Pump Specifications	Single Suction, Single-Stage
Cylinders	Double Cylinders	Inlet Diameter	3" (80 mm)
Bore × Stroke	78 × 72 mm	Outlet Diameter	2.5" (65 mm)
Maximum Output	27 HP (20 kW)	Number of Outlets	1 or 2
Fuel Type	Gasoline (92# and above)	Outlet Valve Type	Flat Check Valve
Fuel Tank Capacity	7 L	Priming System	Rotary Vane Vacuum Pump
Fuel System	Solenoid Valve Carburetor	Suction Time	≤ 15 s
Lubrication System	Forced Lubrication	Maximum Suction Head	9 m
Engine Oil Capacity	1.5 L	Maximum Pump Head	90 m
Starter	Manual / Electric Start (Remote Start Optional)	Rated Flow Rate	870 L/min
Ignition Method	Transistor Electronic Ignition	Rated Pressure	0.6 MPa
Fuel Consumption	7 L/h	Net Weight	85 kg

### Size (mm)

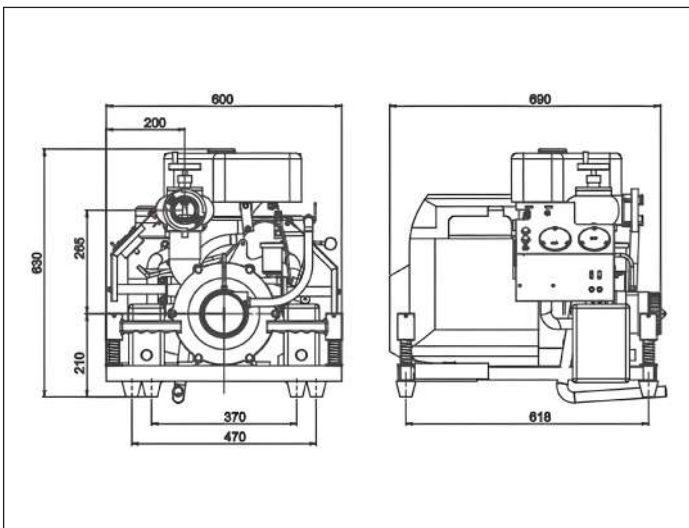

### Advantages

#### Large-Capacity Vacuum Pump

The improved vacuum pump chamber delivers twice the exhaust capacity of the original design. This allows air to be evacuated more quickly, enabling faster water discharge.

#### Automatic Shutdown Protection Device

Equipped with an oil protection system, the engine automatically shuts down when the lubrication oil level falls below the required level, preventing internal damage caused by insufficient lubrication.

# PORTABLE FIRE PUMP GASOLINE ENGINE



## TYPE **FPF6.0/12-FR**

### Engine

FIREFEX FR500-V  
4 STROKES, AIR COOLED  
GASOLINE ENGINE

### Max. Output

18HP (12Kw)

### Pump performance

500 L/min @ 0.65 MPa  
750 L/min @ 0.60 MPa  
1000 L/min @ 0.35 MPa

### Net weight

58 kg

### Size

570 x 510 x 560 mm



### Main Components

- ▶ Recoil / Electric Start
- ▶ Carbon Fiber Sliding Vanes
- ▶ 180° Rotatable Discharge Valve
- ▶ Automatic Shutdown Protection Device
- ▶ 360° Rotatable Handle

### Remote Control

The optional remote control device allows users to start, stop, pressurize, and depressurize the equipment remotely, enabling convenient and efficient operation from a distance.

### Safety Protection Device

The safety protection device effectively prevents high-temperature exhaust gases from coming into direct contact with the human body, reducing the risk of skin burns.

### Low Noise

The well-designed, large-capacity exhaust system effectively absorbs engine noise, significantly reducing noise pollution.

### Automatic Charging Device

The equipment is equipped with an automatic charging function that allows the battery to charge during operation, ensuring it remains fully charged at all times.

### Multiple Device Connection

Using a dedicated connection tool, multiple units can be connected in series and operate simultaneously to enable long-distance water supply.



# PORTABLE FIRE PUMP



## Mobility Meets Firefighting Power

The optional remote control device enables start, shutdown, pressurization, decompression, and other operational functions, allowing convenient and efficient remote operation.

Engine Model	4 Strokes	Pump Type	Single-Stage Centrifugal Pump
Cylinders	Single Cylinder	Inlet Diameter	2.5" (65 mm)
Fuel Type	Gasoline (92# and above)	Outlet Diameter	2.5" (65 mm)
Fuel Tank Capacity	6.5 L	Number of Outlets	1 pc
Fuel System	Carburetor (Manual Choke)	Outlet Valve Type	Flat Check Valve
Lubrication System	Forced Splash Lubrication	Priming System	Rotary Vane Vacuum Pump
Oil Capacity	0.9 L	Suction Time	≤ 12 s
Start Method	Recoil / Electric Start	Maximum Suction Head	9 m
Ignition Method	Transistor Electronic Ignition	Maximum Pump Head	75 m
Fuel Consumption	4.5 L/h	Rated Flow Rate	750 L/min
Net Weight	58 kg	Rated Pressure	0.6 MPa

### Size (mm)

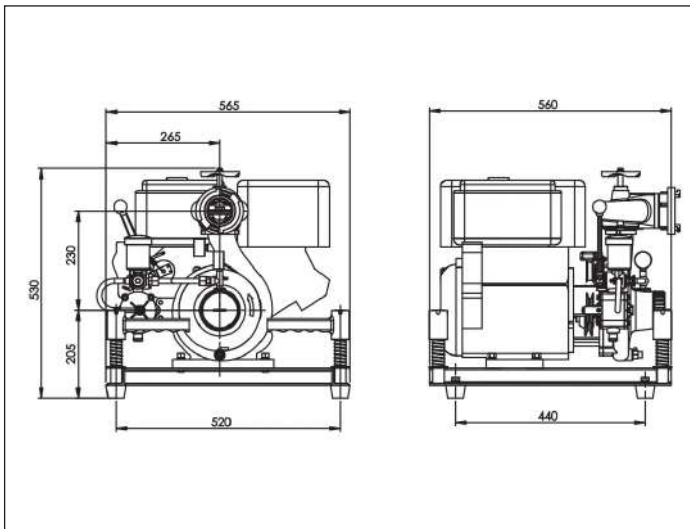

### Performance curve

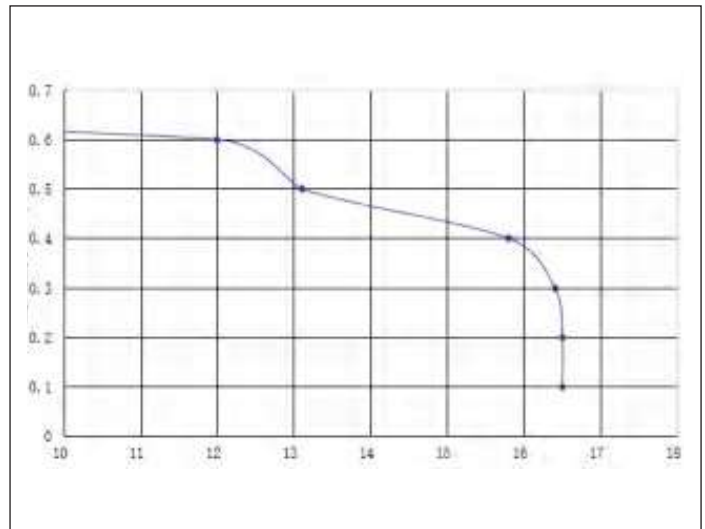

# PORTABLE FIRE PUMP GASOLINE ENGINE



## TYPE FPF6.0/8.5-H

### Engine

HONDA GX390 (389 CC)  
4 STROKES, AIR COOLED  
GASOLINE ENGINE

### Max. Output

13HP (9.6Kw)

### Pump performance

(Tested at 3 m Suction Depth)

270 L/min @ 0.8 MPa

540 L/min @ 0.6 MPa

720 L/min @ 0.4 MPa

### Net weight

54 kg

### Size

575 x 560 x 515 mm



### Main Components

- ▶ Manual / Electric Start (Dual Starters)
- ▶ Oil-Free Vacuum Pump
- ▶ Medium Flow, Medium Head
- ▶ Carbon Fiber Sliding Vanes
- ▶ 180° Rotatable Outlet Valve
- ▶ Automatic Shutdown Protection Device
- ▶ Original Imported Gasoline Engine
- ▶ Quick-Release Outlet Valve

### Intelligent Control Panel

The new integrated intelligent control panel features one-button start, automatic water priming, and water discharge functions. It requires no professional training, offers simple operation, and ensures reliable equipment performance.

### Oil Shortage Protection Device

The oil protection system automatically prevents the engine from operating when the oil level is too low, helping to avoid damage caused by insufficient lubrication.

### Original Engine Power Upgrade

By improving the air intake system and optimizing fuel injection timing, the engine achieves better air-fuel mixing for more complete combustion. The ignition coil is also enhanced to deliver stronger spark performance, resulting in increased engine power and overall efficiency.

### Multiple Device Connection

Using a dedicated connection tool, multiple units can be connected in series and operate simultaneously to enable long-distance water supply.



# PORTABLE FIRE PUMP



## Mobility Meets Firefighting Power

### Maintenance-Free Battery

Equipped with an electric start function, the system effectively prevents environmental pollution caused by electrolyte leakage. The battery is stable and reliable, ensuring the equipment can start normally anytime and anywhere.

### Automatic Charging Device

The equipment is equipped with an automatic charging function that allows the battery to be charged during operation, ensuring it remains fully charged at all times.

Cylinders	Single Cylinder	Pump Specification	Single Suction, Double Stage
Bore x Stroke	88 × 64 mm	Inlet Diameter	2.5" (65 mm)
Max. Output	13 HP (9.6 kW)	Outlet Diameter	2.5" (65 mm)
Fuel Type	Gasoline 92# and above	Number of outlets	1 or 2 Outlets
Fuel Tank	6.5 L	Outlet valve type	Flat Check Valve
Fuel System	Carburetor ~ Manual Choke	Priming System	Oil-Free Vacuum Pump
Lubrication System	Splash Lubrication	Suction Time	≤10 s
Engine Oil Capacity	1.2 L	Maximum Suction Head	9 m
Starter	Manual / Electric Start	Maximum Pump Head	90 m
Ignition Method	Transistor Electronic Ignition	Rated flow	540 L/min
Fuel Consumption	2.5 L/h	Rated Pressure	0.6 MPa

### Size (mm)

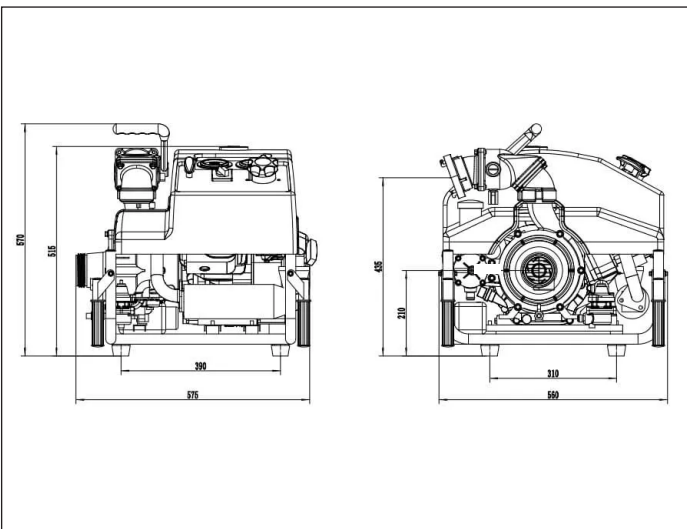

### Performance curve

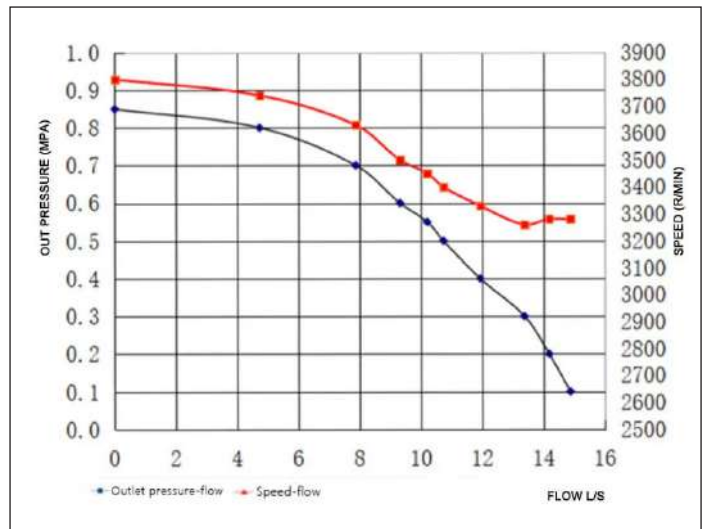

# PORTABLE FIRE PUMP GASOLINE ENGINE



## TYPE **FPF5.5/12.5-F**

### Engine

FIREFEX F190FD  
4 STROKES, AIR COOLED  
GASOLINE ENGINE

### Max. Output

15HP (11Kw)

### Pump performance

(Tested at 3 m Suction Depth)

500 L/min @ 0.65 MPa

750 L/min @ 0.55 MPa

1000 L/min @ 0.35 MPa

### Net weight

56 kg

### Size

560 x 565 x 530 mm



### Main Components

- ▶ Manual / Electric Start (Dual Starters)
- ▶ Rotary Vane Vacuum Pump
- ▶ Medium Flow, Medium Head
- ▶ Carbon Fiber Sliding Vanes
- ▶ 90° Rotatable Outlet Valve
- ▶ Automatic Shutdown Protection Device
- ▶ Original Imported Gasoline Engine
- ▶ Dual-Side Exhaust Pipes

### Safety Protection Device

The safety protection device effectively prevents hot gases discharged from the engine from coming into direct contact with the operator, reducing the risk of burns.

### Low Noise

The well-designed, large-capacity exhaust cylinder effectively absorbs engine noise, significantly reducing noise pollution.

### Automatic Charging Device

The equipment is equipped with an automatic charging system, allowing the battery to charge itself during operation and ensuring it remains fully charged.

### Multiple Device Connection

Using a dedicated connection tool, multiple units can be connected in series and operate simultaneously to enable long-distance water supply.

### Remote Control

The optional remote control allows operators to start, stop, pressurize, depressurize, and manage other functions of the equipment remotely, providing convenient and safe operation.



# PORTABLE FIRE PUMP



## Mobility Meets Firefighting Power

A high-powered, easy-to-carry fire pump engineered for superior performance and mobility. Delivering strong, consistent water pressure, it is ready to operate anytime, anywhere—providing dependable fire protection across emergency scenarios, industrial environments, and remote areas.

Engine Model	4 Strokes	Pump Specifications	Single Suction, Single-Stage
Cylinders	Single Cylinder	Inlet Diameter	2.5" (65 mm)
Bore × Stroke	90 × 66 mm	Outlet Diameter	2.5" (65 mm)
Maximum Output	15 HP (11 kW)	Number of Outlets	1
Fuel Type	Gasoline 92# and above	Outlet Valve Type	Flat Check Valve
Fuel Tank Capacity	6.5 L	Priming System	Rotary Vane Vacuum Pump
Fuel System	Carburetor (Manual Choke)	Suction Time	≤ 15 s
Lubrication System	Splash Lubrication	Maximum Suction Head	9 m
Engine Oil Capacity	0.9 L	Maximum Pump Head	75 m
Starter	Manual / Electric Start	Rated Flow Rate	750 L/min
Ignition Method	Transistor Electronic Ignition	Rated Pressure	0.55 MPa
Fuel Consumption	3.5 L/h	Net Weight	56 kg

### Size (mm)

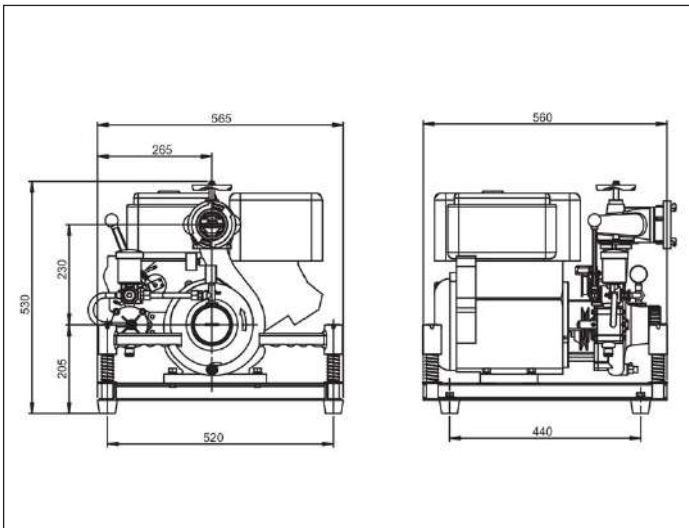

### Performance curve

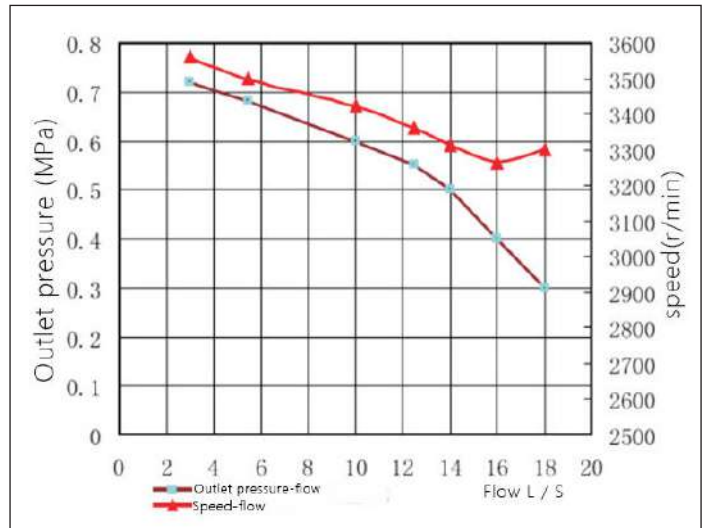

# PORTABLE FIRE PUMP GASOLINE ENGINE



## TYPE FPF5.5/10-H

### Engine

HONDA GX390 – 389 CC  
4 STROKES, AIR COOLED  
GASOLINE ENGINE

### Max. Output

13HP (9.6Kw)

### Pump performance

(Tested at 3 m Suction Depth)

400 L/Min @ 0.65 MPa

600 L/Min @ 0.55 MPa

1000 L/Min @ 0.35 MPa

### Net weight

56 kg

### Size

565 x 560 x 530 mm



### Main Components

- ▶ Manual / Electric Start (Dual Starters)
- ▶ Rotary Vane Vacuum Pump
- ▶ Carbon Fiber Slide
- ▶ Oil Level Indicator
- ▶ 180° Rotatable Outlet Valve
- ▶ Automatic Shutdown Protection Device
- ▶ 360° Rotatable Handle

### Maintenance-Free Battery

Equipped with an electric start, the maintenance-free battery effectively prevents environmental pollution caused by electrolyte leakage. At the same time, it remains stable and reliable, ensuring the equipment starts normally anytime and anywhere.

### Safety Protection Device

The safety protection device effectively prevents hot gases discharged from the engine from coming into direct contact with the operator, reducing the risk of burns.

### Low Noise

The well-designed, large-capacity exhaust cylinder effectively absorbs engine noise, significantly reducing noise pollution.

### Multiple Device Connection

Using a dedicated connection tool, multiple units can be connected in series and operate simultaneously to enable long-distance water supply.

### Remote Control

The optional remote control allows operators to start, stop, pressurize, depressurize, and manage other functions of the equipment remotely, providing convenient and safe operation.



# PORTABLE FIRE PUMP



## Mobility Meets Firefighting Power

A high-powered, easy-to-carry fire pump engineered for superior performance and mobility. Delivering strong, consistent water pressure, it is ready to operate anytime, anywhere—providing dependable fire protection across emergency scenarios, industrial environments, and remote areas.

Engine Model	4 Strokes	Pump Specifications	Single Suction, Single-Stage
Cylinders	Single Cylinder	Inlet Diameter	2.5" (65 mm)
Bore × Stroke	88 × 64 mm	Outlet Diameter	2.5" (65 mm)
Maximum Output	13 HP (9.6 kW)	Number of Outlets	1
Fuel Type	Gasoline 92# and above	Outlet Valve Type	Flat Check Valve
Fuel Tank Capacity	6.5 L	Priming System	Rotary Vane Vacuum Pump
Fuel System	Carburetor (Manual Choke)	Suction Time	≤ 15 s
Lubrication System	Splash Lubrication	Maximum Suction Head	9 m
Engine Oil Capacity	0.9 L	Maximum Pump Head	65 m
Starter	Manual / Electric Start	Rated Flow Rate	600 L/min
Ignition Method	Transistor Electronic Ignition	Rated Pressure	0.55 MPa
Fuel Consumption	3.5 L/h	Net Weight	56 kg

### Size (mm)

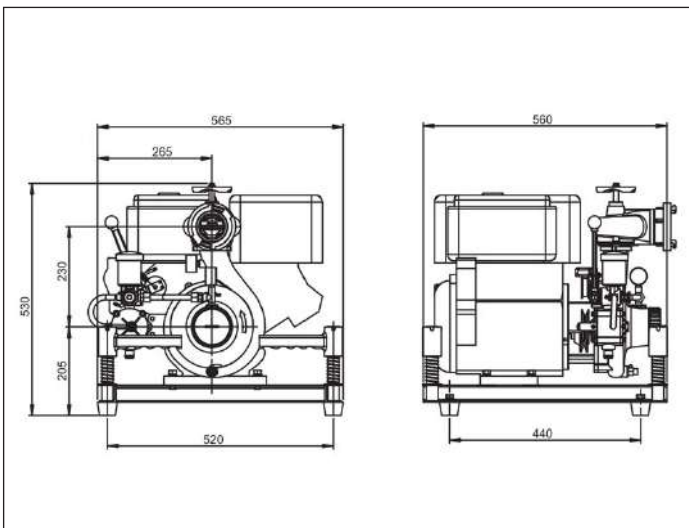

### Performance curve

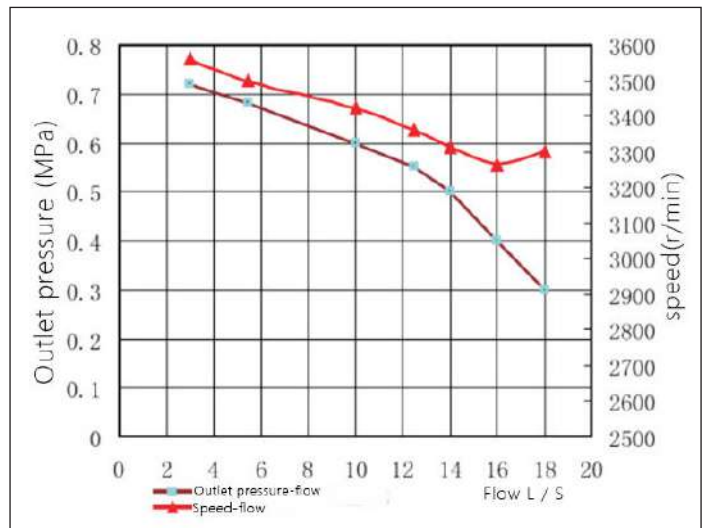

# PORTABLE FIRE PUMP GASOLINE ENGINE



## TYPE **FPF5.5/10-F**

### Engine

FIREFEX F188FD – 389 CC  
4 STROKES, AIR COOLED  
GASOLINE ENGINE

### Max. Output

13HP (9.6Kw)

### Pump performance (Tested at 3 m Suction Depth)

400 L/Min @ 0.65 MPa

600 L/Min @ 0.55 MPa

1000 L/Min @ 0.35 MPa

### Net weight

56 kg

### Size

565 x 560 x 530 mm



### Main Components

- ▶ Manual / Electric Start (Dual Starters)
- ▶ Rotary Vane Vacuum Pump
- ▶ Carbon Fiber Slide
- ▶ Oil Level Indicator
- ▶ 180° Rotatable Outlet Valve
- ▶ Automatic Shutdown Protection Device
- ▶ 360° Rotatable Handle

### Maintenance-Free Battery

Equipped with an electric start, the maintenance-free battery effectively prevents environmental pollution caused by electrolyte leakage. At the same time, it remains stable and reliable, ensuring the equipment starts normally anytime and anywhere.

### Safety Protection Device

The safety protection device effectively prevents hot gases discharged from the engine from coming into direct contact with the operator, reducing the risk of burns.

### Low Noise

The well-designed, large-capacity exhaust cylinder effectively absorbs engine noise, significantly reducing noise pollution.

### Multiple Device Connection

Using a dedicated connection tool, multiple units can be connected in series and operate simultaneously to enable long-distance water supply.

### Remote Control

The optional remote control allows operators to start, stop, pressurize, depressurize, and manage other functions of the equipment remotely, providing convenient and safe operation.



# PORTABLE FIRE PUMP



## Mobility Meets Firefighting Power

A high-powered, easy-to-carry fire pump engineered for superior performance and mobility. Delivering strong, consistent water pressure, it is ready to operate anytime, anywhere—providing dependable fire protection across emergency scenarios, industrial environments, and remote areas.

Engine Model	4 Strokes	Pump Specifications	Single Suction, Single-Stage
Cylinders	Single Cylinder	Inlet Diameter	2.5" (65 mm)
Bore × Stroke	88 × 64 mm	Outlet Diameter	2.5" (65 mm)
Maximum Output	13 HP (9.6 kW)	Number of Outlets	1
Fuel Type	Gasoline 92# and above	Outlet Valve Type	Flat Check Valve
Fuel Tank Capacity	6.5 L	Priming System	Rotary Vane Vacuum Pump
Fuel System	Carburetor (Manual Choke)	Suction Time	≤ 15 s
Lubrication System	Splash Lubrication	Maximum Suction Head	9 m
Engine Oil Capacity	0.9 L	Maximum Pump Head	65 m
Starter	Manual / Electric Start	Rated Flow Rate	600 L/min
Ignition Method	Transistor Electronic Ignition	Rated Pressure	0.55 MPa
Fuel Consumption	3.5 L/h	Net Weight	56 kg

### Size (mm)

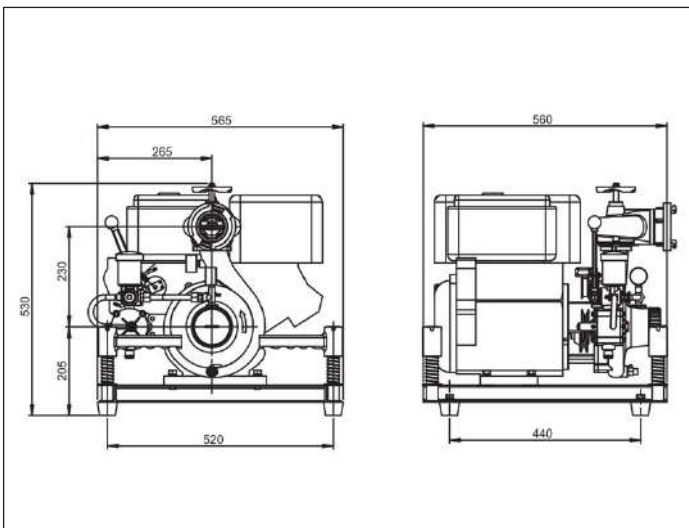

### Performance curve

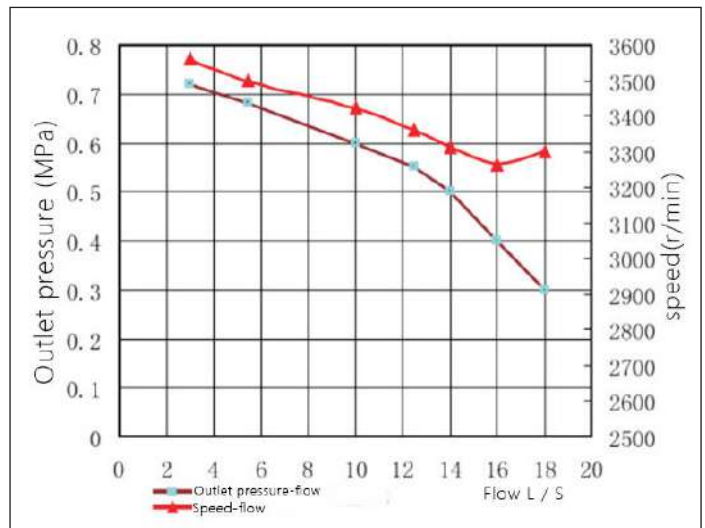

# PORTABLE FIRE PUMP GASOLINE ENGINE



## TYPE FPF4.0/7-F

### Engine

FIREFEX F177FD DISPLACEMENT 270CC  
4 STROKES, AIR COOLED  
GASOLINE ENGINE

### Max. Output

9HP (6.7Kw)

### Pump performance

(Tested at 3 m Suction Depth)

150 L/Min @ 0.50 MPa  
420 L/Min @ 0.40 MPa  
780 L/Min @ 0.30 MPa

### Net weight

42 kg, 30 kg

### Size

Hand Lift: 510 × 520 × 510 mm  
Frame Type: 520 × 500 × 440 mm

[Optional Frame Type]



### Main Components

- ▶ Manual / Electric Start (2 Starters)
- ▶ Rotary Vane Vacuum Pump
- ▶ Carbon Fiber Slide
- ▶ Fuel Level Indicator
- ▶ 180° Rotatable Outlet Valve
- ▶ Automatic Shutdown Protection Device
- ▶ 360° Rotatable Handle



### Maintenance-Free Battery

Equipped with an electric start, the maintenance-free battery effectively prevents environmental pollution caused by electrolyte leakage. At the same time, it remains stable and reliable, ensuring the equipment starts normally anytime and anywhere.

### Low Noise

The well-designed, large-capacity exhaust cylinder effectively absorbs engine noise, significantly reducing noise pollution.

### Automatic Charging Device

The equipment is equipped with an automatic charging function that allows the battery to charge during operation, ensuring it remains fully charged at all times.

### Multiple Device Connection

Using a dedicated connection tool, multiple units can be connected in series and operate simultaneously to enable long-distance water supply.



# PORTABLE FIRE PUMP



## Mobility Meets Firefighting Power

### Remote Control

The optional remote control device allows users to start, stop, pressurize, depressurize, and perform other operations remotely, ensuring convenient and efficient control

### All-Round Protection Frame

The machine frame is integrally formed from high-strength carbon steel, making the unit lightweight, durable, and reliable. It is one of the lightest models in its class.

### Rotatable Hand Lift

The hand-lift frame is constructed from a high-strength structure with an aluminum alloy handle, which can rotate 360° for easy handling and transport.

Engine Model	4 Strokes	Pump Specifications	Single Suction, Single-Stage
Cylinders	Single Cylinder	Inlet Diameter	2.5" (65 mm)
Maximum Output	9 HP (6.7 kW)	Outlet Diameter	2.5" (65 mm)
Fuel Type	Gasoline 92# and above	Number of Outlets	1
Fuel Tank Capacity	6 L	Outlet Valve Type	Flat Check Valve
Fuel System	Carburetor - Manual Choke	Priming System	Rotary Vane Vacuum Pump
Lubrication System	Splash Lubrication	Suction Time	≤ 15 s
Engine Oil Capacity	0.7 L	Maximum Suction Head	9 m
Starter	Manual / Electric Start	Maximum Flow	1000 L/min
Ignition Method	Transistor Electronic Ignition	Maximum Pump Head	45 m
Fuel Consumption	3 L/h	Rated Flow	420 L/min
Net Weight	42 kg	rated Pressure	0.4 Mpa

### Size (mm)

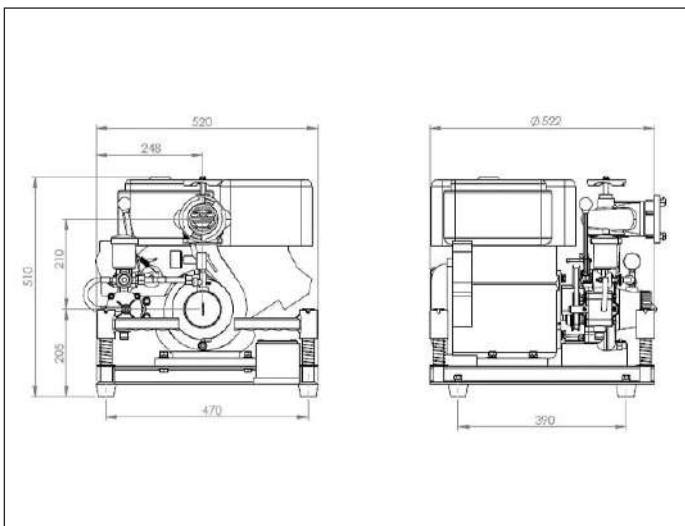

### Performance curve

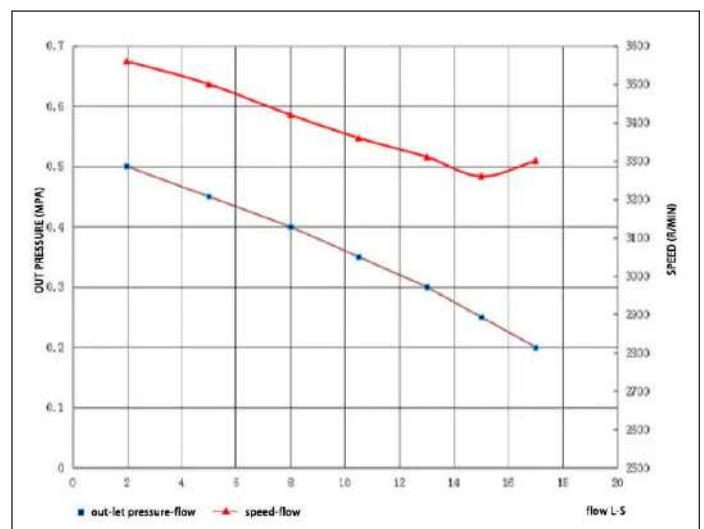

# PORTABLE FIRE PUMP DIESEL ENGINE



## TYPE FPF6.0/20-F

### Engine

FIREFEX  
4 STROKES, AIR COOLED  
DIESEL ENGINE 1.247 L

### Max. Output

25HP (19kw)

### Pump performance

1200 L/min @ 0.60 MPa  
1410 L/min @ 0.50 MPa  
1500 L/min @ 0.40 MPa

### Net weight

127 kg

### Size

800 x 640 x 900 mm



### Main Components

- ▶ Electric Start
- ▶ Bronze Vacuum Pump
- ▶ Carbon Fiber Slide
- ▶ 90° Rotatable Outlet Valve
- ▶ Diesel Engine
- ▶ Automatic Shutdown Protection Device

### Large-Capacity Vacuum Pump

The improved vacuum pump chamber delivers twice the exhaust capacity of the original design. This allows air to be evacuated more quickly, enabling faster water discharge.

### Low Noise

The well-designed, large-capacity exhaust cylinder effectively absorbs engine noise, significantly reducing noise pollution.

### Original Engine Power Upgrade

By improving the air intake system and optimizing fuel injection timing, the engine achieves more complete combustion. The ignition system is also enhanced by adjusting the primary coil voltage, resulting in stronger secondary coil performance and increased overall engine power.

### Multiple Devices Connected

Using a dedicated connection tool, multiple units can be connected in series and operate simultaneously to enable long-distance water supply.



# PORTABLE FIRE PUMP



## Mobility Meets Firefighting Power

A high-powered, diesel-engine fire pump engineered for superior performance and durability. Delivering strong, consistent water pressure, it is ready to operate anytime, anywhere—providing reliable fire protection across emergency situations, industrial sites, and remote locations.

### Maintenance-Free Battery

Equipped with an electric start function, the battery effectively prevents environmental pollution caused by electrolyte leakage. At the same time, it is stable and reliable, ensuring the equipment starts normally anytime, anywhere.

Engine Model	4-Stroke	Pump Type	Single-Stage Centrifugal Pump
Cylinders	2 Cylinders	Inlet Diameter	3" (80 mm)
Fuel Type	0# and Higher Quality Diesel	Outlet Diameter	2.5" (65 mm)
Fuel Tank	12 L	Number of Outlets	1 PC
Fuel System	Direct Injection	Outlet Valve Type	Flat Check Valve
Lubrication System	Forced Splash Lubrication	Priming System	Oil-Free Rotary Vane Bronze Vacuum Pump
Oil Capacity	3.5 L	Suction Time	≤ 19 s
Starter	Electric Start	Maximum Suction Head	9 m
Ignition	Compression Ignition	Maximum Pump Head	85 m
Fuel Consumption	6 L/h	Maximum Flow	1500 L/min
Net Weight	127 kg	Maximum Pressure	0.8 MPa

### Size (mm)

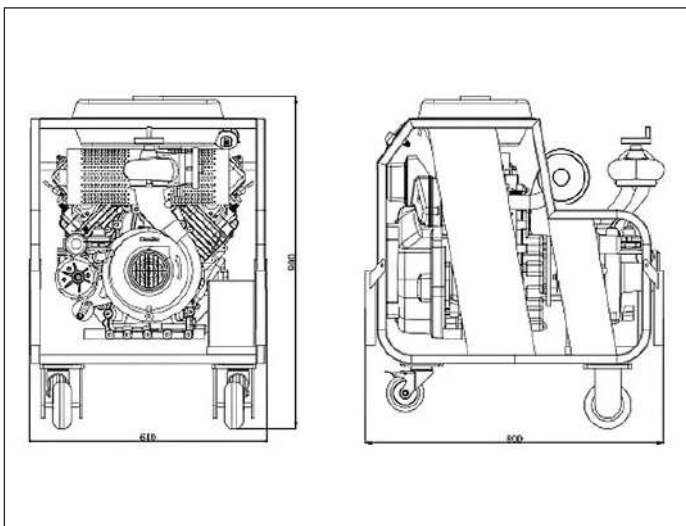

### Performance curve

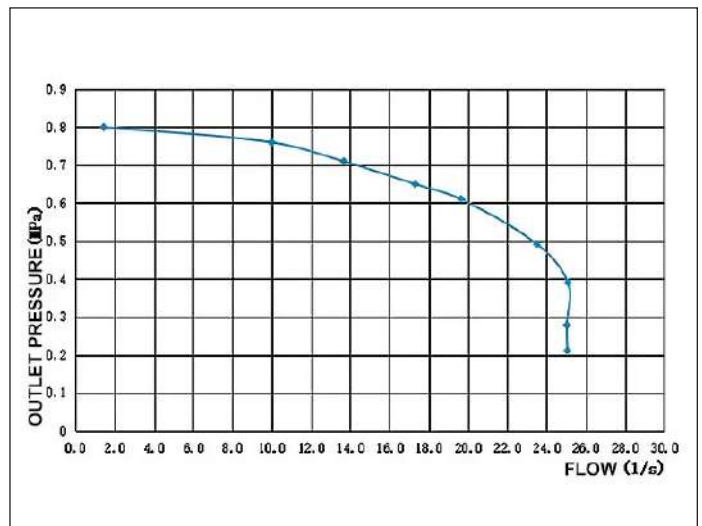

# PORTABLE FIRE PUMP DIESEL ENGINE



## TYPE **FPF5.5/10-F**

### Engine

FIREFEX F192FB  
4 STROKES, AIR COOLED  
DIESEL ENGINE

### Max. Output

15HP (11Kw)

### Pump performance

(Tested under 3 m Suction Depth)

300 L/min @ 0.60 MPa

600 L/min @ 0.55 MPa

1000 L/min @ 0.30 MPa

### Net weight

68 kg

### Size

590 x 560 x 570 mm



### Main Components

- ▶ Manual/Electric Start (2 Starters)
- ▶ Rotary Vane Vacuum Pump
- ▶ Carbon Fiber Slide
- ▶ 180° Rotatable Outlet Valve
- ▶ Automatic Shutdown Protection Device
- ▶ Fuel Level Indicator
- ▶ Diesel Engine

### Maintenance-Free Battery

Equipped with an electric start, the maintenance-free battery effectively prevents environmental pollution caused by electrolyte leakage. At the same time, it remains stable and reliable, ensuring the equipment starts normally anytime and anywhere.

### Low Noise

The well-designed, large-capacity exhaust cylinder effectively absorbs engine noise, significantly reducing noise pollution.

### Safety Protection Device

The safety protection device effectively prevents hot gases discharged from the engine from coming into direct contact with the operator, reducing the risk of burns.

### Multiple Devices Connected

Using a dedicated connection tool, multiple units can be connected in series and operate simultaneously to enable long-distance water supply.

### Remote Control

The optional remote control allows operators to start, stop, pressurize, depressurize, and manage other functions of the equipment remotely, providing convenient and safe operation.



# PORTABLE FIRE PUMP



## Mobility Meets Firefighting Power

A high-powered, diesel-engine fire pump engineered for superior performance and durability. Delivering strong, consistent water pressure, it is ready to operate anytime, anywhere—providing reliable fire protection across emergency situations, industrial sites, and remote locations.

Engine Model	4-Stroke	Pump Specification	Single-Stage Centrifugal Pump
Cylinders	Single Cylinder	Inlet Diameter	2.5" (65 mm)
Maximum Output	15 HP (11 kW)	Outlet Diameter	2.5" (65 mm)
Fuel Type	Diesel 0# and below	Number of Outlets	1 PC
Fuel Tank Capacity	6.5 L	Outlet Valve Type	Flat Check Valve
Fuel System	Direct Fuel Injection	Priming System	Rotary Vane Vacuum Pump
Lubrication System	Splash Lubrication	Suction Time	≤ 15 s
Engine Oil Capacity	0.9 L	Maximum Suction Head	9 m
Starter	Manual / Electric Start	Maximum Flow	1000 L/min
Ignition Method	High-Pressure Atomization	Maximum Pump Head	65 m
Fuel Consumption	3.5 L/h	Rated Flow	600 L/min
Net Weight	68 kg	Rated Pressure	0.55 MPa

### Size (mm)

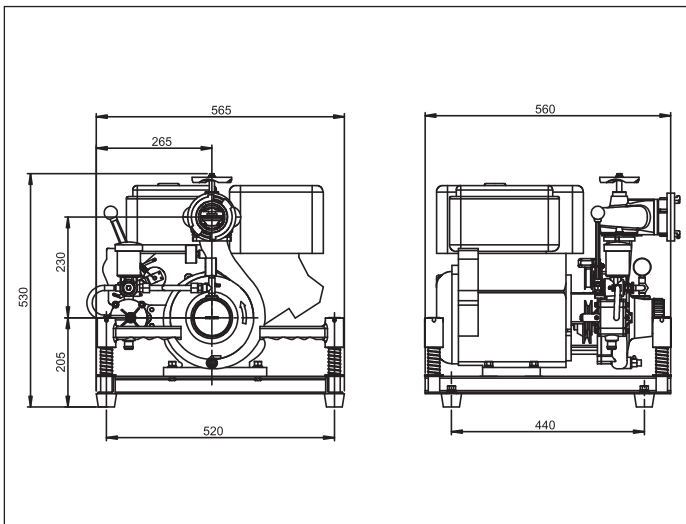

### Performance curve

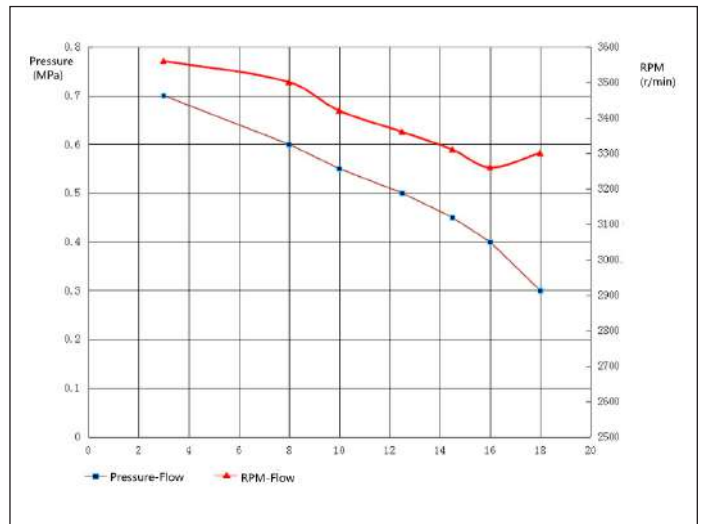

# FLOATING FIRE PUMP GASOLINE ENGINE



## TYPE FFP3.0/8-H

### Engine

HONDA GXV160 (DISPLACEMENT 160 CC)  
4 STROKES, AIR COOLED  
GASOLINE ENGINE

### Max. Output

5.5HP (4Kw)

### Size

690 × 550 × 450 mm

### Net Weight

24 kg

### Maximum Flow

1000 L/min



The Firefex Floating Fire Pump is a lightweight, high-performance solution designed for fast and efficient water supply in critical situations. Operating directly on water surfaces, it ensures quick deployment, powerful output, and reliable performance—perfect for firefighting, emergency response, and remote operations.

### Advantages

The floating pump is compact, lightweight, and easy to operate. It can draw water directly from ponds, rivers, wells, pools, and other sources, offering high flexibility, strong water output, extended range, and easy maintenance. It is ideal for firefighting scenarios or temporary water supply in urban and rural areas where fire trucks have limited access.

### Main Features

- ▶ Original Imported Engine
- ▶ High-Strength Aluminum-Magnesium Alloy Die-Casting Pump Body
- ▶ Lightweight Design with Polyurethane Pontoon
- ▶ Suitable for Fresh Water, Seawater, and Sewage (Free of Large Particles)
- ▶ Equipped with a Bottom Filter to Remove Debris from Water
- ▶ Easy to Operate and Carry
- ▶ Minimum Water Absorption Depth: 5 cm



# FLOATING FIRE PUMP



## Mobility Meets Firefighting Power

The Firefex Floating Fire Pump is a lightweight, high-performance solution designed for fast and efficient water supply in critical situations. Operating directly on water surfaces, it ensures quick deployment, strong output, and reliable performance for firefighting, emergency response, and remote operations. Its compact and durable design, combined with a high-strength aluminum-magnesium alloy pump body and polyurethane pontoon, provides easy handling, low maintenance, and long-lasting use. With remote start/stop, adjustable pressure control, flexible water sourcing from rivers, ponds, and wells, as well as high head, large flow, and a minimum water absorption depth of just 5 cm, it delivers powerful performance even in challenging environments—offering key advantages such as rapid deployment, operational flexibility, and dependable performance. The following are the specifications.

Engine Model	4-Stroke	Pump Specification	Single Suction, Single Stage
Cylinders	Single Cylinder	Inlet Diameter	2.5" (65 mm)
Maximum Output	5.5 HP (4 kW)	Outlet Diameter	2.5" (65 mm)
Fuel Type	Gasoline 92# and above	Number of Outlets	1 PC
Fuel Tank Capacity	2.5 L	Priming System	Auto Water Diversion
Fuel System	Solenoid Valve - Carburetor	Minimum Suction Head	0.5 m
Engine Oil Capacity	0.6 L	Maximum Flow	1000 L/min
Starter	Manual	Maximum Pump Head	45 m
Ignition Method	Transistor Electronic Ignition	Rated Flow	480 L/min
Fuel Consumption	1.5 L/h	Rated Pressure	0.3 MPa

### Details & Dimensions

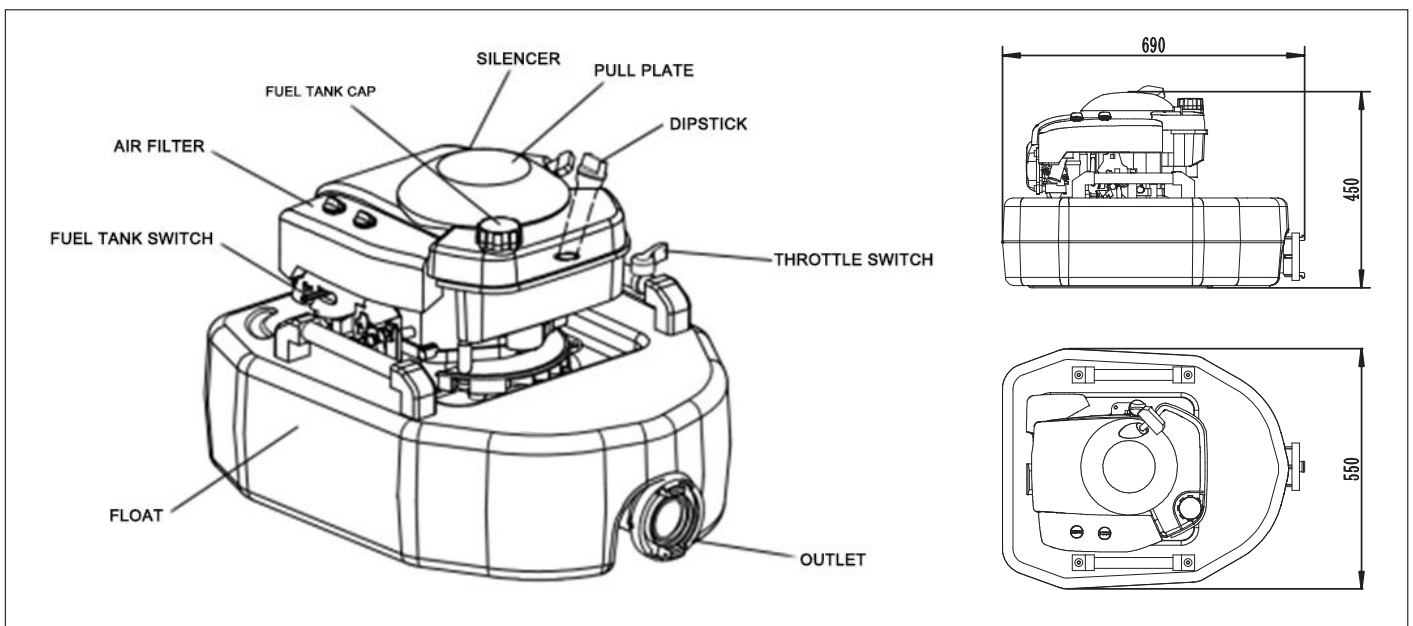

# FLOATING FIRE PUMP GASOLINE ENGINE



## TYPE FFP4.0/10-H

### Engine

HONDA GXV390 (DISPLACEMENT 390 CC)  
4 STROKES, AIR COOLED  
GASOLINE ENGINE

### Pump Performance

600 L/min @ 0.40 MPa

### Maximum Power

13 HP (9.6 kW)

### Net Weight

47.5 kg

### Size

830 × 770 × 490 mm



The Fireflex Floating Fire Pump is a lightweight, high-performance solution designed for fast and efficient water supply in critical situations. Operating directly on water surfaces, it ensures quick deployment, powerful output, and reliable performance perfect for firefighting, emergency response, and remote operations.

### Advantages

The floating pump is compact, lightweight, and easy to operate. It can draw water directly from ponds, rivers, wells, pools, and other sources, offering high flexibility, strong water output, extended range, and easy maintenance. It is ideal for firefighting scenarios or temporary water supply in urban and rural areas where fire trucks have limited access.

### Main Features

- ▶ Original Imported Engine
- ▶ High-Strength Aluminum-Magnesium Alloy Die-Casting Pump Body
- ▶ Lightweight Design with Polyurethane Pontoon
- ▶ Suitable for Fresh Water, Seawater, and Sewage (Free of Large Particles)
- ▶ Equipped with a Bottom Filter to Remove Debris from Water
- ▶ Easy to Operate and Carry
- ▶ High Head, Large Flow
- ▶ Minimum Water Absorption Depth: 50 cm



# FLOATING FIRE PUMP



## Mobility Meets Firefighting Power

The Fireflex Floating Fire Pump is a lightweight, high-performance solution designed for fast and efficient water supply in critical situations. Operating directly on water surfaces, it ensures quick deployment, strong output, and reliable performance for firefighting, emergency response, and remote operations. Its compact and durable design, combined with a high-strength aluminum-magnesium alloy pump body and polyurethane pontoon, provides easy handling, low maintenance, and long-lasting use. With remote start/stop, adjustable pressure control, flexible water sourcing from rivers, ponds, and wells, as well as high head, large flow, and a minimum water absorption depth of just 5 cm, it delivers powerful performance even in challenging environments—offering key advantages such as rapid deployment, operational flexibility, and dependable performance. The following are the specifications.

Engine Model	4-Stroke	Pump Specification	Single Suction, Single Stage
Cylinders	Single Cylinder	Inlet Diameter	3" (80 mm)
Maximum Output	13HP (9.6 kW)	Outlet Diameter	2.5" (65 mm)
Fuel Type	Gasoline 92# and above	Number of Outlets	1 PC
Fuel Tank Capacity	4 L	Priming System	Auto Water Diversion
Fuel System	Solenoid Valve - Carburetor	Minimum Suction Head	0.5 m
Engine Oil Capacity	1.8 L	Maximum Flow	1200 L/min
Starter	Manual	Maximum Pump Head	60 m
Ignition Method	Transistor Electronic Ignition	Rated Flow	600 L/min
Fuel Consumption	3.5 L/h	Rated Pressure	0.4 MPa

### Size (mm)

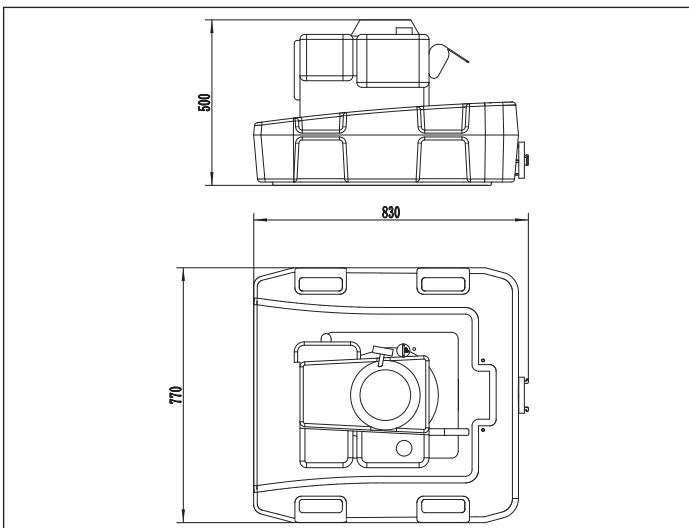

### Performance curve

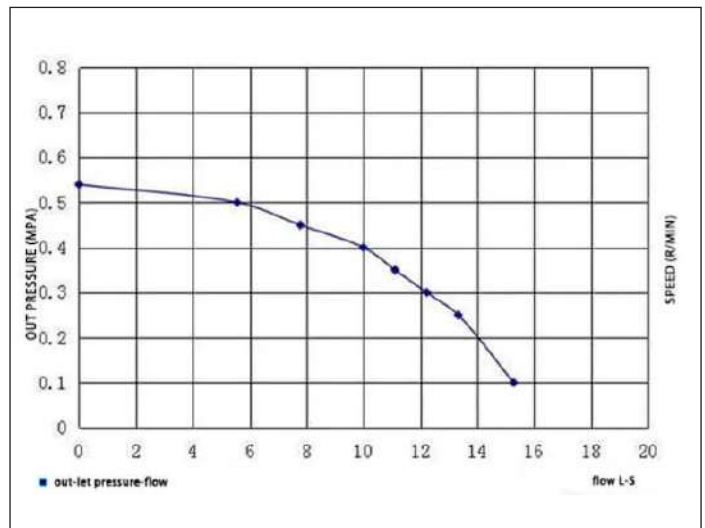

# FLOATING FIRE PUMP GASOLINE ENGINE



## TYPE **FFP4.0/15-F**

### Engine

FIREFEX F1P92F (DISPLACEMENT 452 CC)  
4 STROKES, AIR COOLED  
GASOLINE ENGINE

### Starter

Electric / Remote Start

### Maximum Power

15 HP (11 kW)

### Net Weight

55 kg

### Size

830 × 770 × 500 mm



The Fireflex Floating Fire Pump is a lightweight, high-performance solution designed for fast and efficient water supply in critical situations. Operating directly on water surfaces, it ensures quick deployment, powerful output, and reliable performance perfect for firefighting, emergency response, and remote operations.

### Advantages

The floating pump is compact, lightweight, and easy to operate. It can draw water directly from ponds, rivers, wells, pools, and other sources, offering high flexibility, strong water output, extended range, and easy maintenance. It is ideal for firefighting scenarios or temporary water supply in urban and rural areas where fire trucks have limited access.

### Main Features

- ▶ Remote Start/Stop, Adjustable Water Pressure
- ▶ High-Strength Aluminum-Magnesium Alloy Die-Casting Pump Body
- ▶ Lightweight Design with Polyurethane Pontoon
- ▶ Suitable for Fresh Water, Seawater, and Sewage (Free of Large Particles)
- ▶ Equipped with a Bottom Filter to Remove Debris from Water
- ▶ Easy to Operate and Carry
- ▶ High Head, Large Flow
- ▶ Minimum Water Absorption Depth: 5 cm



# FLOATING FIRE PUMP



## Mobility Meets Firefighting Power

The Fireflex Floating Fire Pump is a lightweight, high-performance solution designed for fast and efficient water supply in critical situations. Operating directly on water surfaces, it ensures quick deployment, strong output, and reliable performance for firefighting, emergency response, and remote operations. Its compact and durable design, combined with a high-strength aluminum-magnesium alloy pump body and polyurethane pontoon, provides easy handling, low maintenance, and long-lasting use. With remote start/stop, adjustable pressure control, flexible water sourcing from rivers, ponds, and wells, as well as high head, large flow, and a minimum water absorption depth of just 5 cm, it delivers powerful performance even in challenging environments—offering key advantages such as rapid deployment, operational flexibility, and dependable performance. The following are the specifications.

Engine Model	4-Stroke	Pump Specification	Single Suction, Single Stage
Cylinders	Single Cylinder	Inlet Diameter	3" (80 mm)
Maximum Output	15HP (11 kW)	Outlet Diameter	2.5" (65 mm)
Fuel Type	Gasoline 92# and above	Number of Outlets	1 PC
Fuel Tank Capacity	4 L	Priming System	Auto Water Diversion
Fuel System	Solenoid Valve - Carburetor	Minimum Suction Head	0.5 m
Engine Oil Capacity	0.9 L	Maximum Flow	1500 L/min
Starter	Manual / Electric / Remote start	Maximum Pump Head	60 m
Ignition Method	Transistor Electronic Ignition	Rated Flow	900 L/min
Fuel Consumption	3.5 L/h	Rated Pressure	0.4 MPa

### Size (mm)

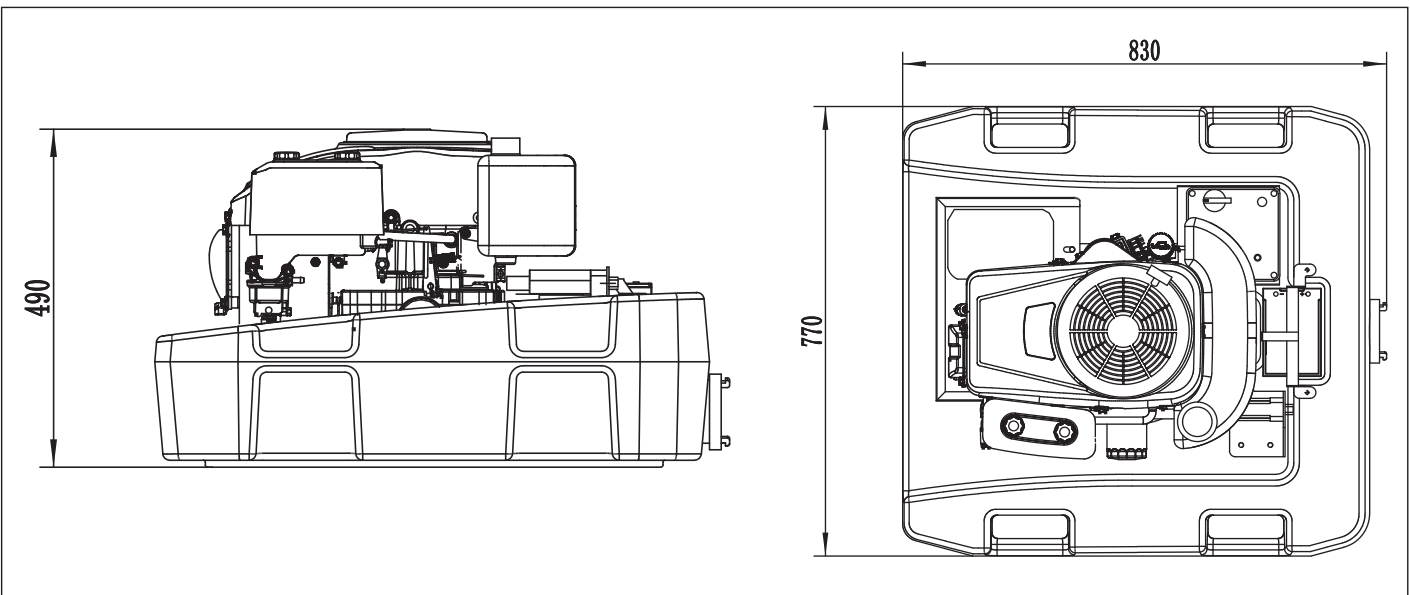

# HIGH-LIFT FOREST FIRE PUMP

## GASOLINE ENGINE



TYPE **FHF40/6-32**

### Engine

FIREFEX  
4 STROKES, FORCED AIR COOLED  
GASOLINE ENGINE

### Starter

Manual / Electric Start

### Maximum Power

7 HP (5 kW)

### Net Weight

40 kg

### High Lift

500 m

### Size

745 × 620 × 540 mm



### High-Lift Forest Fire Pump with a gasoline engine

is a powerful, portable solution designed for rapid response in forest and remote environments. Engineered for high head performance, it delivers strong and consistent water pressure over long distances, making it ideal for wildfire suppression and emergency operations. Featuring a genuine Italian pump with high precision and superior performance, the unit is equipped with an integrated manual/electric starter system for easy operation, along with a lightweight, corrosion-resistant aluminum alloy structure. Powered by an advanced Japanese engine system, it offers stable performance, easy maintenance with a split-type crankcase and cylinder block design, and the ability to operate continuously for over 60 hours. Additional safety features include speed protection and an automatic shutdown system for low engine oil, ensuring maximum reliability. With its lightweight design, easy start capability, and ability to draw water directly from natural sources such as rivers and lakes, it provides key advantages including high mobility, efficiency, and dependable firefighting performance in hard-to-reach areas.

### Main Features

- ▶ Genuine Italian Pump
- ▶ Lightweight, Easy to Start
- ▶ High Precision, Superior Performance
- ▶ Integrated Manual / Electric Starters
- ▶ Aluminum Alloy, Anti-Corrosion and Lightweight
- ▶ Continuous Operation for Over 60 Hours
- ▶ Speed Protection Function, Automatic Protection for Low Engine Oil
- ▶ Advanced Japanese Power System, Split-Type Crankcase and Cylinder Block, Easy to Maintain



# HIGH-LIFT FOREST FIRE PUMP

*Mobility Meets Firefighting Power*

Engine Model	4-Stroke	Pump Specification	Italian PA Diaphragm Pump
Cylinders	Single Cylinder	Inlet Diameter	1" (25.4 mm)
Output Power	7 HP (5 kW)	Outlet Diameter	1" (25.4 mm)
Fuel Type	Gasoline 92# and above	Number of Outlets	1 PC
Rated Speed	3600 rpm	Priming System	Auto Water Diversion
Cooling System	Forced Air Cooling	Suction Time	≤ 30 s
Lubrication System	Splash Lubrication	Maximum Pump Head	500 m
Fuel Tank Capacity	2.5 L	Rated Flow	36 L/min
Engine Oil Capacity	0.6 L	Rated Pressure	4 MPa
Starter	Manual / Electric Start	Net Weight	40 kg
Fuel Consumption	1.5 L/h	Size	745 × 620 × 540 mm

## Size (mm)

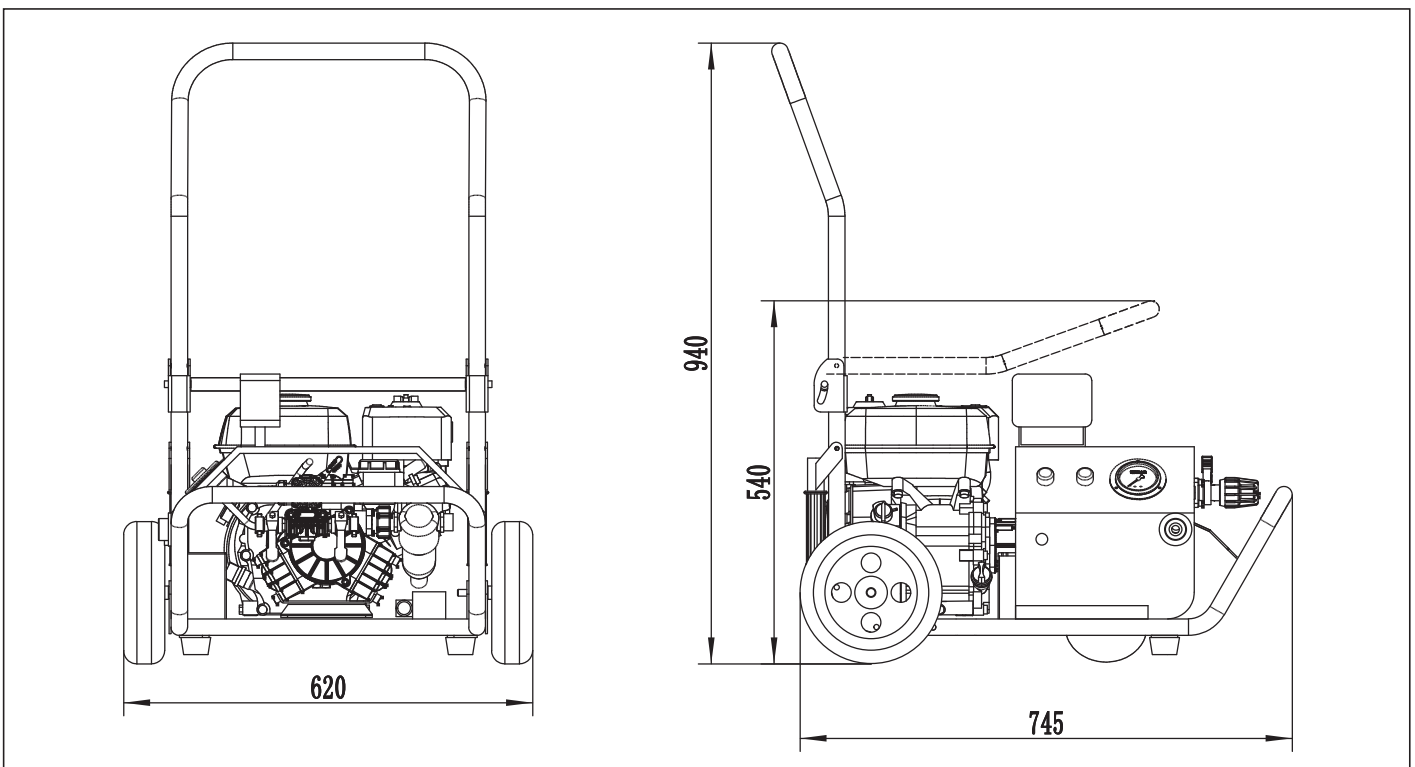

# HIGH-LIFT FOREST FIRE PUMP GASOLINE ENGINE



TYPE **FHF10/3.6-K**

## Engine

KOHLER CH440  
4 STROKE, AIR-COOLED  
GASOLINE ENGINE

## Maximum Output

14 HP (10.3 kW)

## Pump Performance (3 m Suction Depth)

220 L/min @ 1.0 MPa  
400 L/min @ 0.8 MPa  
500 L/min @ 0.6 MPa

## Net Weight

67 kg

## Size

610 × 560 × 600 mm



## Main Components

- ▶ Manual / Electric Starters
- ▶ Optional Remote-Control Equipment
- ▶ Automatic Charging Device
- ▶ Automatic Stop Protection Device
- ▶ Genuine Imported Gasoline Engine
- ▶ Kohler Engine

## Maintenance-Free Battery

Equipped with an electric start, this battery prevents environmental pollution from electrolyte leakage. It is stable and reliable, ensuring the equipment starts normally anytime, anywhere.

## Low Noise

The large-capacity exhaust cylinder is designed to absorb engine noise effectively, significantly reducing noise pollution.

## Automatic Charging Device

The equipment is equipped with an automatic charging system, allowing the battery to charge itself during operation and ensuring it remains fully charged.

## Multiple Device Connection

Using a dedicated connection tool, multiple units can be connected in series and operate simultaneously to enable long-distance water supply.



# HIGH-LIFT FOREST FIRE PUMP



## Mobility Meets Firefighting Power

### Performance Advantage – Engine Power Upgrade

The upgraded system improves the air intake and adjusts fuel injection timing to achieve complete combustion. By optimizing the primary coil voltage, the secondary coil delivers stronger magneto-electric performance, resulting in powerful ignition and up to a 25% increase in engine output.

Engine Model	4-Stroke	Pump Type	Single suction, single stage
Cylinders	Single Cylinder	Inlet Diameter	2.5" (65 mm)
Fuel Type	Gasoline 92# and above	Outlet Diameter	1.5" (40 mm)
Fuel Tank Capacity	65 L	Number of Outlets	2
Fuel System	Carburetor – Manual Choke	Outlet Valve Type	Flat Check Valve
Lubrication System	Splash Lubrication	Priming System	Exhaust Prime (Vacuum Pump optional)
Oil Capacity	0.9 L	Suction Time	≤ 15 s
Starter	Manual / Electric Operation (Optional Remote Control)	Maximum Suction Head	6 m
Ignition Method	Transistor Electronic Ignition	Maximum Pump Head	170 m
Fuel Consumption	3.5 L/H	Rated Flow	220 L/min
Net Weight	67 kg	Rated Pressure	1.0 MPa

### Size (mm)

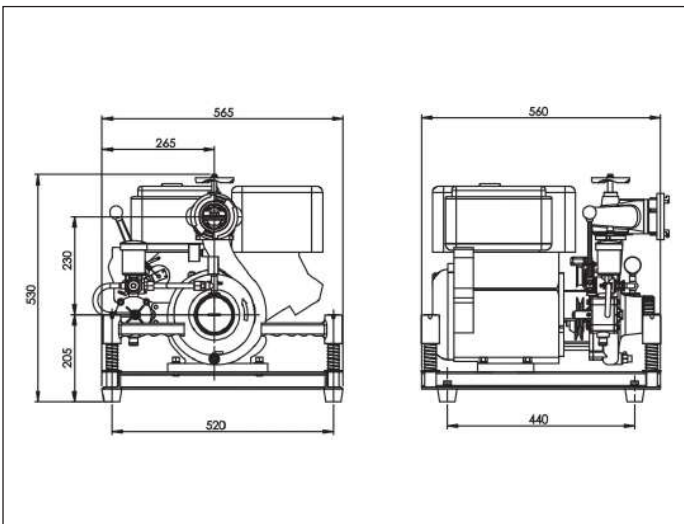

### Performance curve

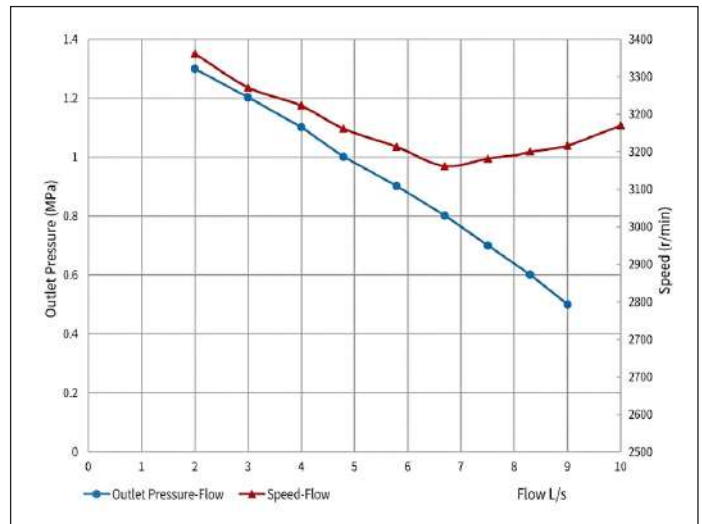

# HIGH-LIFT FOREST FIRE PUMP GASOLINE ENGINE



TYPE **FHF10/3.6-H**

## Engine

HONDA GX390  
4 STROKE, AIR-COOLED  
GASOLINE ENGINE

## Maximum Output

13 HP (9.6 kW)

## Pump Performance (3 m Suction Depth)

220 L/min @ 1.0 MPa  
400 L/min @ 0.8 MPa  
500 L/min @ 0.6 MPa

## Net Weight

65 kg

## Size

610 × 560 × 600 mm



## Main Components

- ▶ Manual / Electric Starters
- ▶ Optional Remote-Control Equipment
- ▶ Automatic Charging Device
- ▶ Automatic Stop Protection Device
- ▶ Genuine Imported Gasoline Engine
- ▶ Kohler Engine

## Maintenance-Free Battery

Equipped with an electric start, this battery prevents environmental pollution from electrolyte leakage. It is stable and reliable, ensuring the equipment starts normally anytime, anywhere.

## Low Noise

The large-capacity exhaust cylinder is designed to absorb engine noise effectively, significantly reducing noise pollution.

## Automatic Charging Device

The equipment is equipped with an automatic charging system, allowing the battery to charge itself during operation and ensuring it remains fully charged.

## Multiple Device Connection

Using a dedicated connection tool, multiple units can be connected in series and operate simultaneously to enable long-distance water supply.



# HIGH-LIFT FOREST FIRE PUMP



## Mobility Meets Firefighting Power

### Performance Advantage – Engine Power Upgrade

The upgraded system improves the air intake and adjusts fuel injection timing to achieve complete combustion. By optimizing the primary coil voltage, the secondary coil delivers stronger magneto-electric performance, resulting in powerful ignition and up to a 25% increase in engine output.

Engine Model	4-Stroke	Pump Type	Single suction, single stage
Cylinders	Single Cylinder	Inlet Diameter	2.5" (65 mm)
Fuel Type	Gasoline 92# and above	Outlet Diameter	1.5" (40 mm)
Fuel Tank Capacity	65 L	Number of Outlets	2
Fuel System	Carburetor – Manual Choke	Outlet Valve Type	Flat Check Valve
Lubrication System	Splash Lubrication	Priming System	Exhaust Prime (Vacuum Pump optional)
Oil Capacity	0.9 L	Suction Time	≤ 15 s
Starter	Manual / Electric Operation (Optional Remote Control)	Maximum Suction Head	6 m
Ignition Method	Transistor Electronic Ignition	Maximum Pump Head	170 m
Fuel Consumption	3.5 L/H	Rated Flow	220 L/min
Net Weight	65 kg	Rated Pressure	1.0 MPa

### Size (mm)

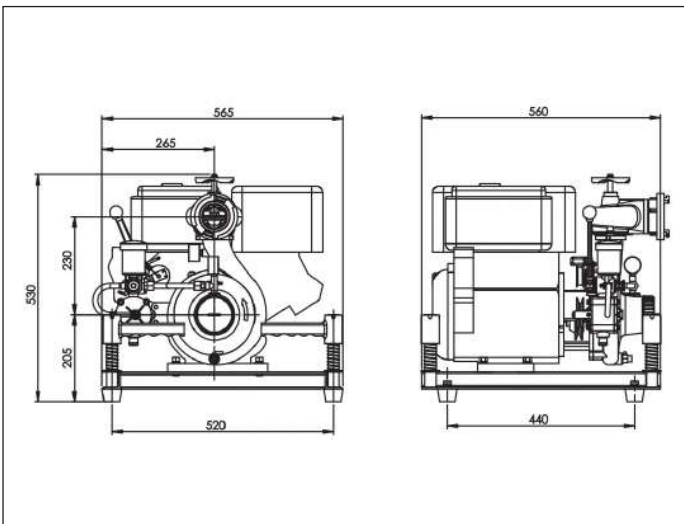

### Performance curve

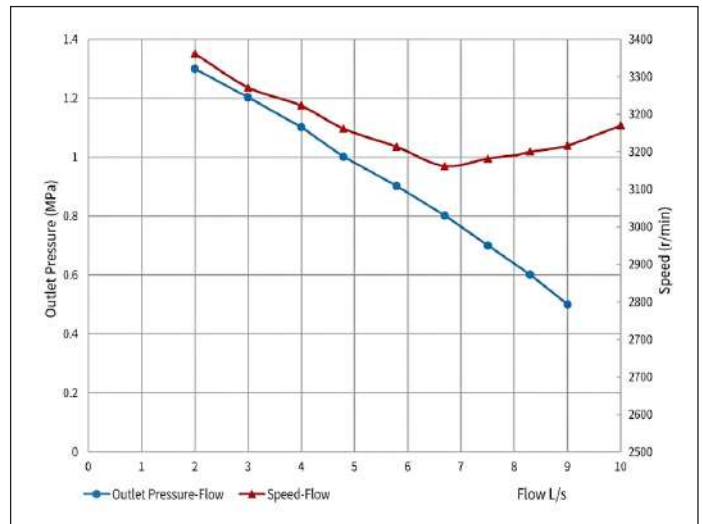

# MULTI FUNCTION FIRE NOZZLE



TYPE **FNLD6.0/III8-B**

**0.6  
MPA**

Nominal  
Pressure

**480  
L/MIN**

Nominal  
Flow

**≤2KG**

Overall  
Weight



## Recoilless Fire Nozzle

- ▶ Versatile Spraying Methods: Achieve a straight water column by rotating the protective sleeve, or switch to multi-flow, foggy flow, and high-pressure flushing. The spray cone at the nozzle tip produces fine mist, absorbing heat, smoke, and dust in an umbrella shape, reducing heat radiation, and supplying fresh air to protect firefighters.

Horseshoe-Type Water Switch: Easy to open and close, ergonomic handle for effortless control and directional accuracy.

Adjustable Sleeve: Correct hose posture and prevent water flow blockage.

Pressure Ratings: Nominal working pressure 6 kg, maximum working pressure 25 kg.

Durable Construction: Made of new aluminum alloy, T5 heat-treated, with anodic oxidation anti-corrosion treatment for long service life.

Easy Maintenance

Standards Compliance: GB8181-2005

## Straight Flow Fire Nozzle

Known for its small reaction force (commonly referred to as a recoilless water nozzle), this direct spray firefighting nozzle is primarily designed for fire-fighting units. It serves as a versatile spraying tool, meeting the technical requirements across various fire scenarios and conditions. When used with a foam device, it can produce high-quality foam via a foam expansion tube. The nozzle is compatible with multiple interfaces, including German-style, British, Japanese, and American-thread connections.

Suction Diameter	65, 50, 40
Max. Working Pressure	25 bar
Flow Adjustment Range	2.5 – 4 – 5 – 6.5 – 8 L/s
Connection	British Type, German Type, Japanese Type
Spray Function	Multi Flow, Straight Flow, Fog Spray
Basic Function	ON/OFF; Hose Maintains Continuous Water Flow
Additional Function	Foam Launcher Tube Equipped; Foam Spraying Available
Material	High-Strength Aerospace Aluminum Alloy
Surface Treatment	Anodic Oxidation Anti-Corrosion Treatment
Remarks	Custom Bronze Body Available
Dimension	275 x 90 x 220 mm

# MULTI FUNCTION FIRE NOZZLE

## Multi-Function Fire Nozzle

Constructed from high-strength aerospace aluminum alloy with anodic oxidation anti-corrosion treatment, this multi-function fire nozzle is designed for durability and long service life. It features an ON/OFF control system that maintains continuous water flow for stable operation. Compatible with British, German, Japanese, and American connection standards, it offers flexible integration across various systems. With a maximum working pressure of 16 bar, it delivers consistent and reliable performance for professional firefighting applications.

### TYPE **FNLD6.0/13III-C**



#### **FNLD6.0/13III-C - Recoilless Fire Nozzle**

Overall Dimensions	330 × 130 × 265 mm
Weight	≤ 2.8 kg
Suction Diameter	80, 65, 50
Nominal Pressure	0.6 MPa
Nominal Flow	780 L/min
Flow Adjustment Range	5 – 6.5 – 8 – 10 – 13 L/s
Spray Function	Multi Flow, Straight Flow, Fog Spray
Additional Function	Foam Launcher Tube Optional; Foam Spraying Available
Maximum Flow	950 L/min

### TYPE **FNLD6.0/5III-D**



#### **FNLD6.0/5III-D - Recoilless Fire Nozzle**

Overall Dimensions	200 × 90 × 220 mm
Weight	≤ 1.3 kg
Suction Diameter	50, 40
Nominal Pressure	0.6 MPa
Nominal Flow	300 L/min
Flow Adjustment Range	2.5-4-5 L/s
Spray Function	Multi Flow, Straight Flow, Fog Spray
Additional Function	Foam Launcher Tube Optional; Foam Spraying Available
Maximum Flow	400 L/min

# MULTI FUNCTION FIRE NOZZLE



## Multi-Function Fire Nozzle

Constructed from high-strength aerospace aluminum alloy with anodic oxidation anti-corrosion treatment, this multi-function fire nozzle is designed for durability and long service life. It features an ON/OFF control system that maintains continuous water flow for stable operation. Compatible with British, German, Japanese, and American connection standards, it offers flexible integration across various systems. With a maximum working pressure of 16 bar, it delivers consistent and reliable performance for professional firefighting applications.

### TYPE FNZM-65



#### FNZM-65 - Straight Flow Water Curtain Fire Nozzle

Overall Dimensions	410 × 90 × 220 mm
Weight	≤ 2.0 kg
Suction Diameter	65, 50, 40
Nominal Pressure	0.6 MPa
Nominal Flow	480 L/min
Spraying function	Straight flow water curtain
Additional Function	Water curtain protection
Maximum Flow	550 L/Min

### TYPE FNSM180-550



#### FNSM180-550 - Double Water Curtain Fire Nozzle

Overall Dimensions	350 × 90 × 220 mm
Weight	≤ 2.5 kg
Suction Diameter	65, 50, 40
Nominal Pressure	0.6 MPa
Nominal Flow	480 L/min
Flow Adjustment Range	180-300-420-550 L/m
Spray Function	Multi Flow, Straight Flow, Fog Spray
Additional Function	Water curtain protection

# MULTI FUNCTION FIRE NOZZLE



## TYPE **FNP8/0.8Z**



### FNP8/0.8Z - Self-suction Air Foam Fire Nozzle

Overall Dimensions	510 × 130 × 265 mm
Weight	≤ 3.5 kg
Suction Diameter	80 / 65 / 50 mm
Nominal Pressure	0.8 MPa
Nominal Flow	480 L/min
Maximum Working Pressure	16 bar
Foam Ratio	1%, 3%, 6%
Connection	British Type, German Type, Japanese Type, American Type
Spray Function	Foam
Additional Function	Adjustable Self-Priming Foam Ratio Mixer
Material	High-Strength Aviation Aluminum Alloy (T5 Heat Treatment)

## TYPE **FNGH-5**



### FNGH-5 - Dry Powder Fire Spray Nozzle

Overall Dimensions	320 × 90 × 220 mm
Weight	≤ 1.7 kg
Suction Diameter	32-65 mm
Nominal Pressure	1 MPa
Spraying Powder Quantity	5 kg
Maximum Working Pressure	16 bar
Spraying Distance	16 m
Connection	Wire Connection, Cannula
Material	High-Strength Aviation Aluminum Alloy (T5 Heat Treatment)

# MULTI FUNCTION FIRE NOZZLE

## TYPE **FNGC-01**



### FNGC - 01 Puncture Water Nozzle

Suction Diameter	65
Overall Dimensions	1 m
Weight	≤ 2.8 Kg
Nominal Flow	12 L/s

## TYPE **FNM-65**



### FNM-65 - Water Curtain Water Nozzle

Suction Diameter	65
Overall Dimensions	260 x 320 x 125 mm
Weight	≤ 4.0 Kg
Nominal Flow	High-Strength Aviation Aluminum Alloy (T5 Heat Treatment)

## TYPE **FNZW-01**



### FNZW-01 - Diversion Water Nozzle

Overall Dimensions	1040 × 125 × 340 mm
Weight	≤ 3 kg
Suction Diameter	65, 50 mm
Maximum Flow	150 L/min
Nominal Pressure	0.5 MPa
Maximum Working Pressure	16 bar
Spraying Distance	20 m
Additional Function	Breaking
Spray Function	Multi-Flow, Straight Flow, Fog Spray
Connection	British Type, German Type, Japanese Type, American Type
Material	Aluminum Alloy, Stainless Steel

# INDOTARA®

## PT. INDOTARA PERSADA

### Our Marketing Office and After Sales Service Center

#### Head Office

50/F, Menara BCA Grand Indonesia  
Jl. M.H. Thamrin No.1  
Jakarta Pusat 10310  
021 - 5011 2224  
dffe@indotara.id



#### Semarang Office

Wisma HSBC Lt. 6 suite 609  
JL. Gajah Mada No.135,  
Semarang, Jawa Tengah - 50134  
024 - 40 300 889  
smg.dffe@indotara.id



#### Marketing Office

Maggiore Business Loft No. 01-02  
Gading Serpong,  
Tangerang - Banten 15332  
021 - 5011 2224  
dffe@indotara.id



#### Medan Office

Sutomo Tower Lantai 5H  
JL. Sutomo Ujung No.28,  
Kota Medan, Sumatera Utara 20235  
061 - 50 300 592  
mdn.dffe@indotara.id



#### Graha Indotara

Millenium Industrial Estate  
JL. Millenium 22 Blok R3 No. 1,  
Cikupa, Tangerang - Banten 15720  
021 - 5011 2224  
dffe@indotara.id



#### Makassar Office

Fajar Graha Pena Lt. 5  
JL. Urip Sumoharjo No. 20,  
Makassar - Sulawesi Selatan 90234  
021 - 5011 2224  
mks.dffe@indotara.id



#### Bandung Office

Wisma HSBC Lt. 6 Suite B  
Jalan Asia Afrika No.116,  
Kota Bandung, Jawa Barat 40112  
021 - 5011 2224  
bdg.dffe@indotara.id



#### Balikpapan Office

Panin Tower Lt. 8 Grand Sudirman  
JL. Jendral Sudirman No.7 Klandasan Ilir,  
Balikpapan Kota - Kalimantan Timur 76114  
021 - 5011 2224  
bpp.dffe@indotara.id



#### Surabaya Office

Japfa Indoland Center, Tower I Lt. 10/1008  
JL. Jendral Basuki Rahmat 129-137  
Surabaya 60271  
031 - 3360 1485  
sby.dffe@indotara.id



#### Bali Office

Benoa Square Lt. 2  
JL. Bypass Ngurah Rai No. 21 A Kedonganan,  
Kuta Badung - Bali Indonesia 80361  
021 - 5011 2224  
bali.dffe@indotara.id



#### Yogyakarta Office

Hartono Mall Yogyakarta Lt. 3  
Kaliwaru, Condongcatur,  
Sleman, Yogyakarta 55281  
021 - 5011 2224  
yog.dffe@indotara.id



#### Singapore Office

Marina Bay Financial Centre Tower 3  
17F, 12 Marina Boulevard  
Singapore - 018982  
021 - 5011 2224  
sing.dffe@indotara.id

